

Dynamics

Question Paper

Level	O Level
Subject	Physics
Exam Board	Cambridge International Examinations
Unit	Newtonian Mechanics
Topic	Dynamics
Booklet	Question Paper

Time Allowed: 74 minutes

Score: /62

Percentage: /100

Grade Boundaries:

- 1 A man pulls a sledge of mass 25 kg across level ground with a horizontal force of 60 N. A constant force of friction of 20 N acts on the sledge.

What is the acceleration of the sledge?

- A** 0.63 m/s^2 **B** 1.6 m/s^2 **C** 2.4 m/s^2 **D** 3.2 m/s^2

- 2 A car moves in a circle at constant speed.

What is the direction of the resultant force acting on the car?

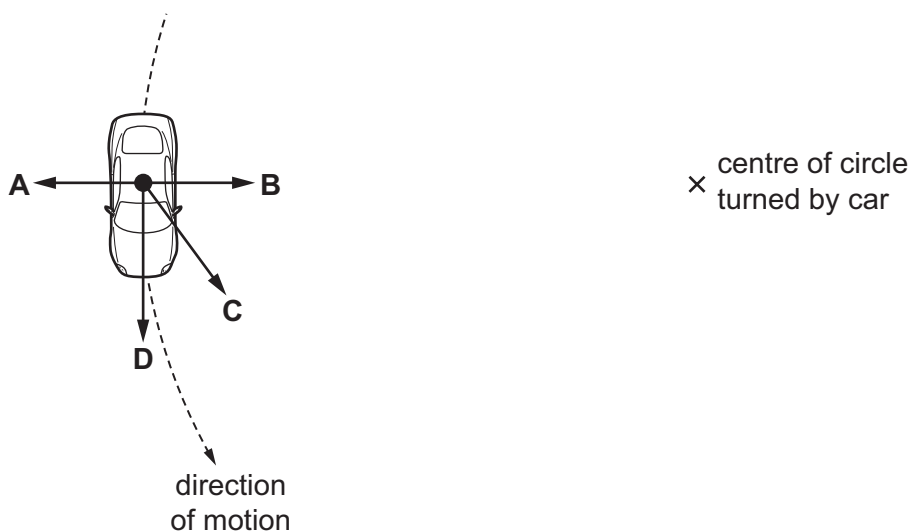

- 1 Four forces act at a point as shown.

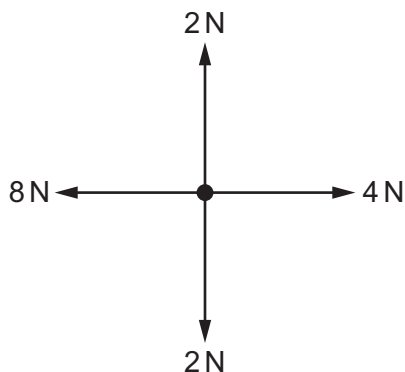

What is the size of the resultant force?

- A** 0 N **B** 4 N **C** 6 N **D** 8 N

- 4 When a car turns a corner at speed, it risks toppling over. Two factors affecting the stability of a car are the height of its centre of mass and the distance between its front wheels.

Which factors make the car most stable?

	centre of mass	distance between front wheels
A	high	small
B	high	large
C	low	small
D	low	large

- 5 A metal ball of mass 0.30 kg and weight 3.0 N is held so that it is below the surface of oil. It experiences an upwards force of 0.30 N.

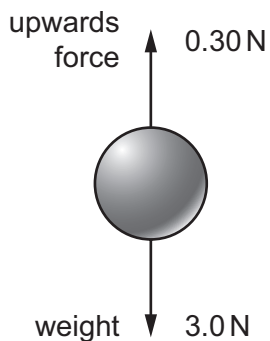

When the ball is released, what is its initial acceleration?

- A** 1.0 m/s^2 **B** 9.0 m/s^2 **C** 10 m/s^2 **D** 11 m/s^2

4

6 The Earth travels in a circular orbit around the Sun at constant speed.

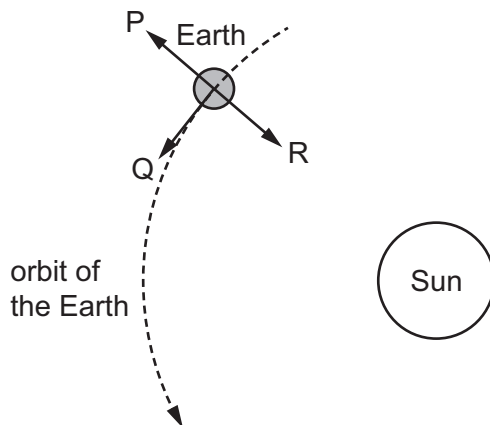

Which arrows show the direction of the acceleration of the Earth and the direction of the velocity of the Earth?

	direction of acceleration	direction of velocity
A	P	Q
B	Q	P
C	Q	R
D	R	Q

7 Which object has the largest resultant force?

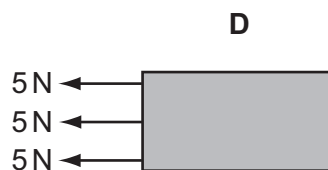
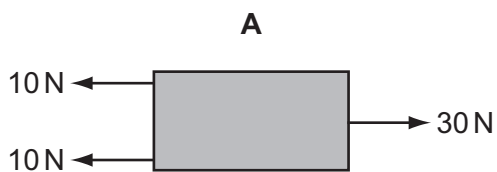

- 8 In which example does friction act in the direction of forward motion of the object on which it acts?
- A on a suitcase accelerating on a conveyor belt
 - B on sandpaper rubbing a wooden block
 - C on the skis of a skier accelerating downhill on smooth snow
 - D on the tyres of a braking car
- 9 The diagram represents the Moon in its orbit around the Earth.

Which arrow represents the direction of the resultant force acting on the Moon at the instant shown?

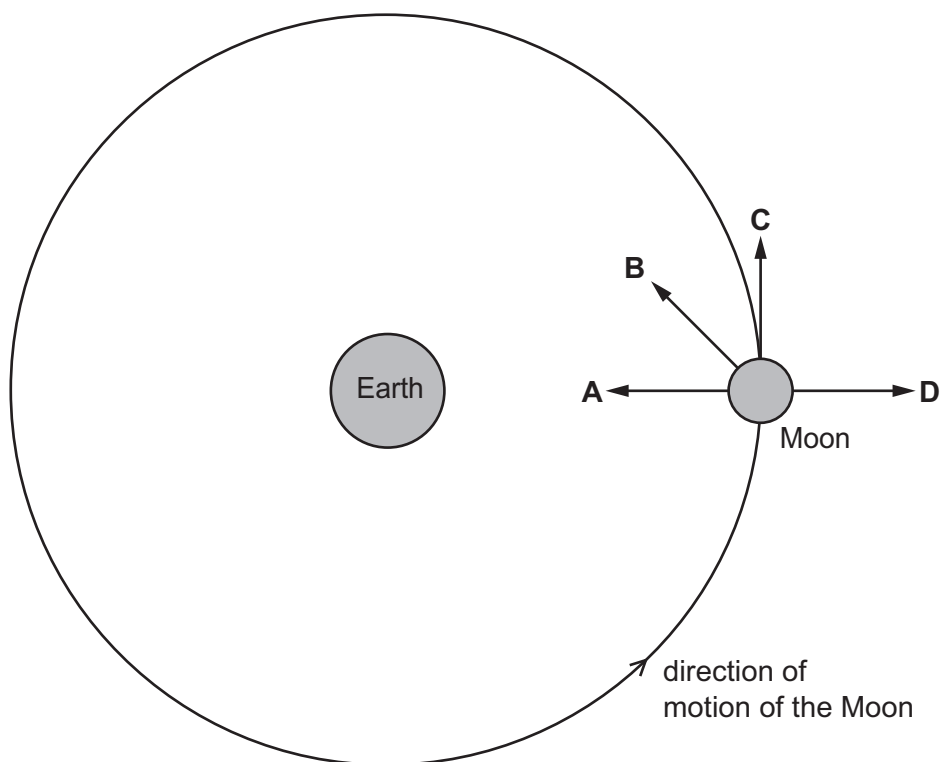

- 10 An apple of mass 0.15 kg and weight 1.5 N falls from a tree. At one point during its fall, the air resistance on the apple is 0.60 N upwards.

What is the acceleration of the apple at this point?

- A 4.0 m/s^2
- B 6.0 m/s^2
- C 10 m/s^2
- D 14 m/s^2

11 Four of the gravitational forces that act between bodies in the Solar System are described below.

- P the force on the Moon due to the Earth
- Q the force on the Earth due to the Sun
- R the force on the Earth due to the Moon
- S the force on the Moon due to the Sun

Which two forces are a Newton’s third law pair (action and reaction)?

- A** P and Q **B** P and R **C** Q and S **D** R and S

12 A man pushes a heavy box along the ground.

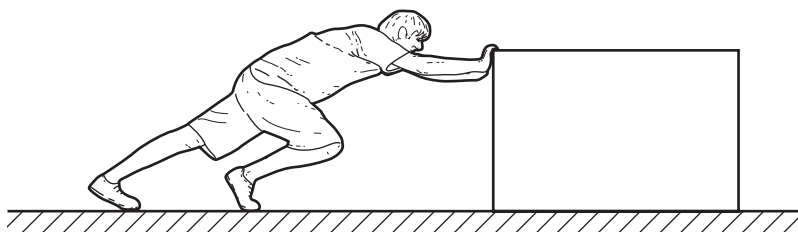

A force acts between the man’s hands and the box.

Another force acts between the man’s feet and the floor.

In which direction do these forces act on the man?

	force on man’s hands	force on man’s feet
A	towards the left	towards the left
B	towards the left	towards the right
C	towards the right	towards the left
D	towards the right	towards the right

13 In which situation is the resultant force on the body equal to zero?

- A** a car turning a corner at constant speed
- B** a rock falling freely on the Moon
- C** a train going up a straight hill at constant speed in a straight line
- D** an aircraft accelerating along a runway in a straight line

14 A satellite is orbiting the Earth.

What is the direction of the force on the satellite causing this circular motion?

- A away from the centre of the Earth
- B in the direction of motion of the satellite
- C in the opposite direction to the motion of the satellite
- D towards the centre of the Earth

15 The diagram shows a block of stone on a rough horizontal surface.

Force P acts on the block as shown.



The block is at rest. A frictional force F acts on the block.

Which row shows the direction and size of F ?

	direction of F	size of F
A	to the left	more than P
B	to the right	more than P
C	to the left	same as P
D	to the right	same as P

- 16 The distance travelled by a car is increasing uniformly as it is driven along a straight road up a hill.

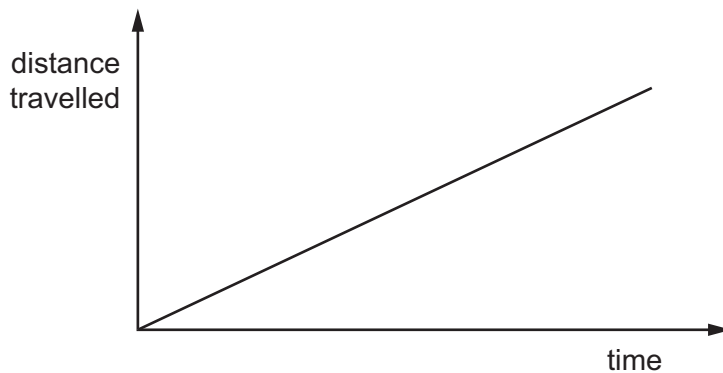

Which quantity for the car is constant but not zero?

- A acceleration
- B gravitational potential energy
- C kinetic energy
- D resultant force

- 17 A boy sits on a playground roundabout (carousel).

The roundabout carries the boy in a horizontal, anticlockwise circle at a constant speed.

The diagram shows the view of the roundabout from above.

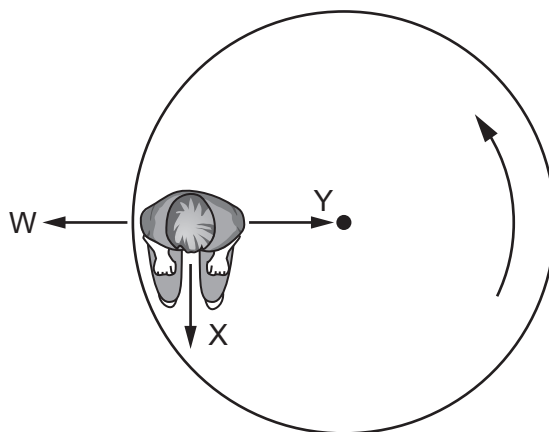

What describes the resultant force on the boy?

- A The resultant force is zero.
 - B The resultant force is in direction W.
 - C The resultant force is in direction X.
 - D The resultant force is in direction Y.
- 18 In a model of an atom, electrons move in circular orbits around a nucleus.
- Which statement about the electrons is correct?
- A The electrostatic force on the electrons is away from the nucleus.
 - B The acceleration of the electrons is towards the central nucleus.
 - C The speed of the electrons varies continuously.
 - D The velocity of the electrons remains constant.

19 A particle P is moving in a horizontal circle about O. P moves at constant speed.

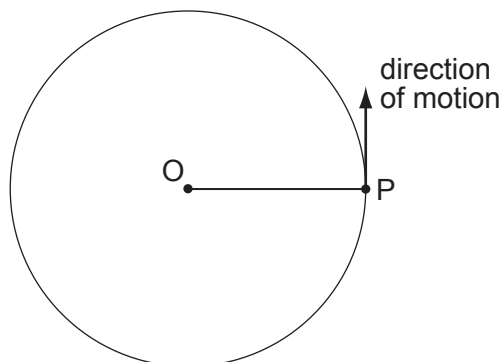

Which statement is true?

- A A force of constant size acts on P in the direction of motion.
- B A force of constant size acts on P towards O.
- C The force on P varies in size as it moves around the circle.
- D There is no resultant force acting on P.

20 A body slides down a frictionless slope as shown.

As the body presses on the surface, the surface pushes back on the body. The force of the surface on the body is sometimes called the reaction force.

In which direction does the reaction force act?

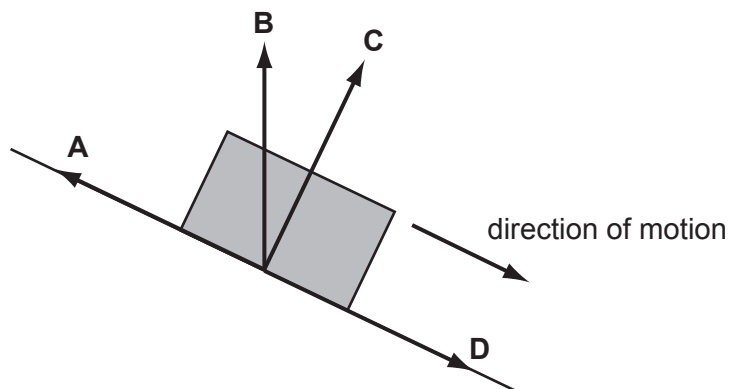

- 21 A car of mass 1500 kg travels along a horizontal road.
It accelerates steadily from 10 m/s to 25 m/s in 5.0 s.
What is the force needed to produce this acceleration?

A 300 N **B** 500 N **C** 4500 N **D** 7500 N

- 22 Balanced forces are acting on a moving body.

What happens to the direction of movement and to the speed of the body?

	direction of movement	speed
A	changes	changes
B	changes	does not change
C	does not change	changes
D	does not change	does not change

- 23 A student kicks a ball horizontally along the ground. As he does so, his foot applies a force to the ball.

At the same time, the ball applies a force to his foot.

How do these forces compare?

- A** The force on the foot is equal to the force on the ball and in the opposite direction.
B The force on the foot is equal to the force on the ball and in the same direction.
C The force on the foot is smaller than the force on the ball and in the opposite direction.
D The force on the foot is smaller than the force on the ball and in the same direction.

24 The diagram shows an aeroplane turning in a horizontal circle at constant speed.

In which direction is there a resultant force?

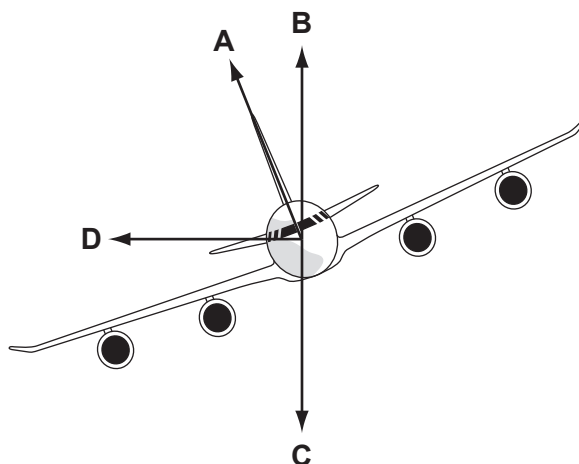

25 A skier of mass 80 kg accelerates down a slope at 2 m/s^2 .

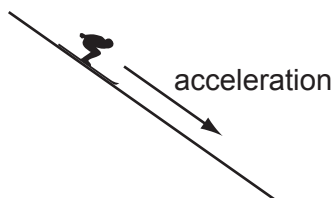

The gravitational field strength g is 10 N/kg .

What is the weight of the skier and the resultant force on the skier?

	weight / N	resultant force / N
A	8	168
B	80	240
C	800	160
D	800	640

26 A hard stone hits the ground and comes to rest almost immediately.

As the stone hits the ground, what is the direction and the size of the force acting on the ground?

- A** downwards and equal to the weight of the stone
- B** downwards and larger than the weight of the stone
- C** upwards and equal to the weight of the stone
- D** upwards and larger than the weight of the stone

27 A car of mass 1500 kg is towing a trailer of mass 1100 kg along a level road. The acceleration of the car is 1.30 m/s^2 .

Ignoring friction and air resistance, what is the driving force on the car?

- A** 1430 N **B** 1950 N **C** 2000 N **D** 3380 N

28 A coin falls through the air from rest, and eventually reaches a constant speed.

Two forces P and Q act on the coin.

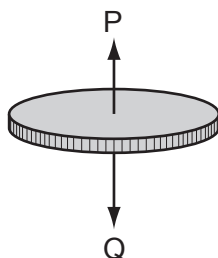

What happens to the force P and to the resultant force acting on the coin before it reaches constant speed?

	force P	resultant force
A	decreases	increases
B	decreases	decreases
C	increases	decreases
D	increases	increases

29 The diagram shows a motorcyclist leaning over in order to move around a corner.

Which force causes him to move around the corner?

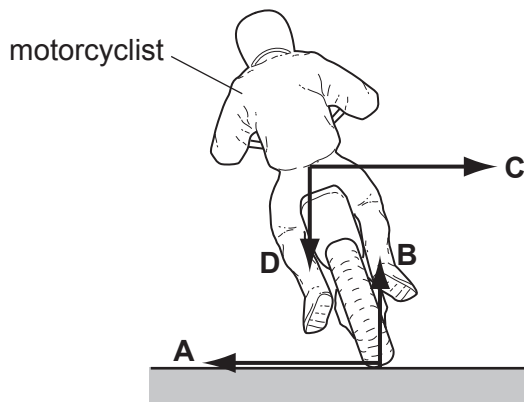

30 An aeroplane is half way along a runway before it takes off.

The arrows show the directions of four forces acting on the aeroplane.

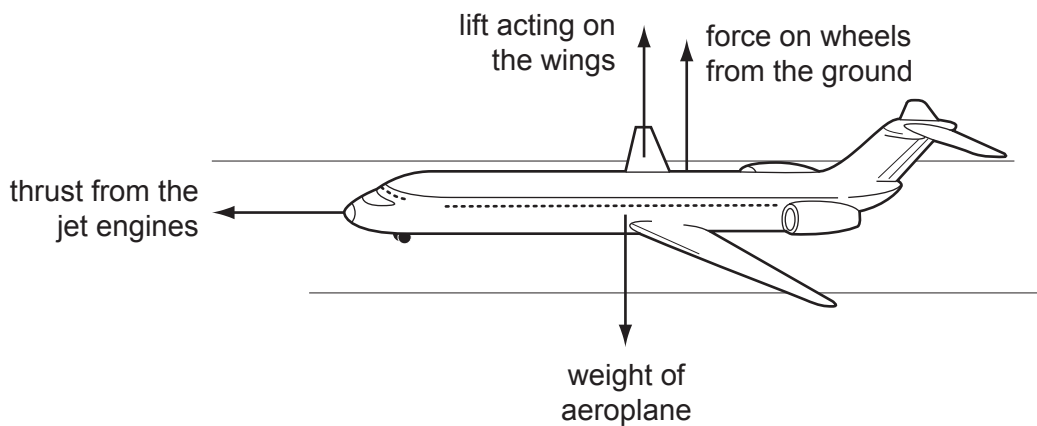

The drag forces on the aeroplane are negligible.

The gravitational field strength g is 10 N/kg .

The acceleration of the aeroplane is 2 m/s^2 .

What is the largest force?

- A** the force on the wheels from the ground
- B** the lift acting on the wings
- C** the thrust from the jet engines
- D** the weight of the aeroplane

- 31 The front wheel of a car is turned in a clockwise direction by the engine as the car accelerates towards the right, as shown in the diagram. There is a force of friction between the wheel and the road.

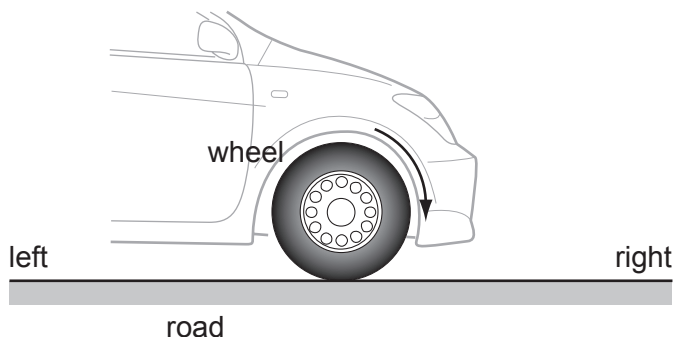

What are the directions of the frictional forces on the wheel of the car and on the road?

	direction of frictional force on wheel	direction of frictional force on road
A	to the left	to the left
B	to the left	to the right
C	to the right	to the left
D	to the right	to the right

- 32 The diagram shows three forces acting on a block.



Which additional force will produce a resultant force of 3 N to the left?

- A** 3 N to the left
- B** 6 N to the right
- C** 9 N to the left
- D** 13 N to the right

33 The diagram shows a firework rocket.

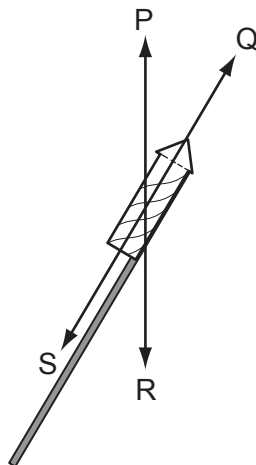

As the rocket flies through the air, three forces act on it. These forces are weight, thrust and air resistance.

What are the three forces?

	thrust	air resistance	weight
A	P	R	S
B	P	S	R
C	Q	R	S
D	Q	S	R

34 An object has a mass of 15 kg. It is pushed horizontally by a force of 40 N. The frictional force is 10 N.

What is the acceleration of the object?

- A** 0.50 m/s² **B** 1.5 m/s² **C** 2.0 m/s² **D** 2.7 m/s²

- 35 The propeller on a boat pushes water backwards with a force of 2000 N. The boat moves through the water against a total resistive force of 1800 N.

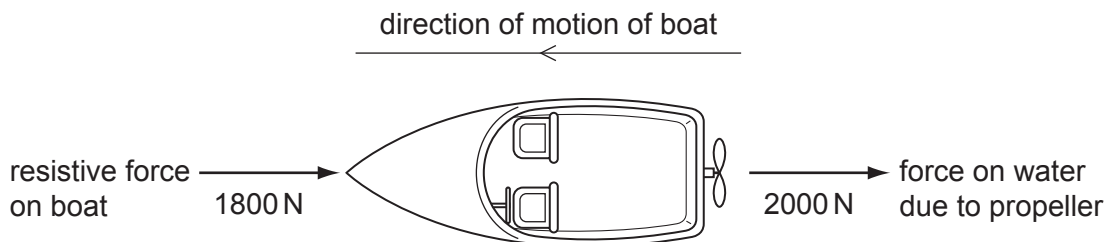

According to Newton's third law, what is the forward force on the propeller due to the water?

- A** 200 N **B** 1800 N **C** 2000 N **D** 3800 N

- 36 An engine pulls a truck at constant speed on a level track.

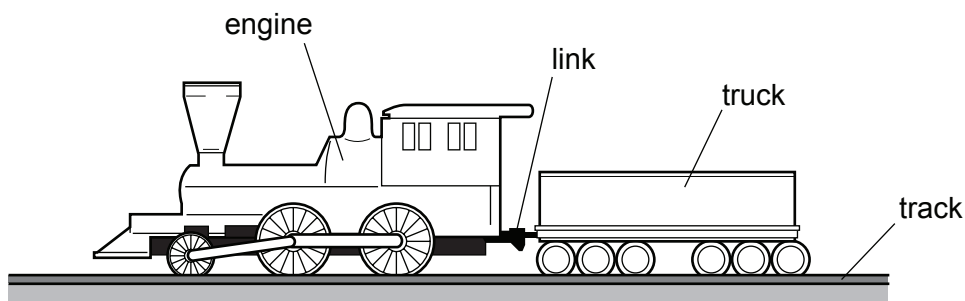

The link between the truck and the engine breaks. The driving force on the engine remains constant.

What effect does this have on the truck and on the engine?

	truck	e
A	slows down	speed stays constant
B	slows down	speeds up
C	stops immediately	speed stays constant
D	stops immediately	speeds up

37 A car travels along a road. The driver stops the car by pushing his foot down on the brake pedal.

What does **not** change if he pushes harder on the brake pedal?

- A the braking distance
- B the braking force
- C the stopping distance
- D the thinking distance

38 An aircraft, flying at a constant height, is gaining speed.

The four forces acting are

- L lift due to the wings
- R air resistance
- T the thrust due to the engines
- W the weight

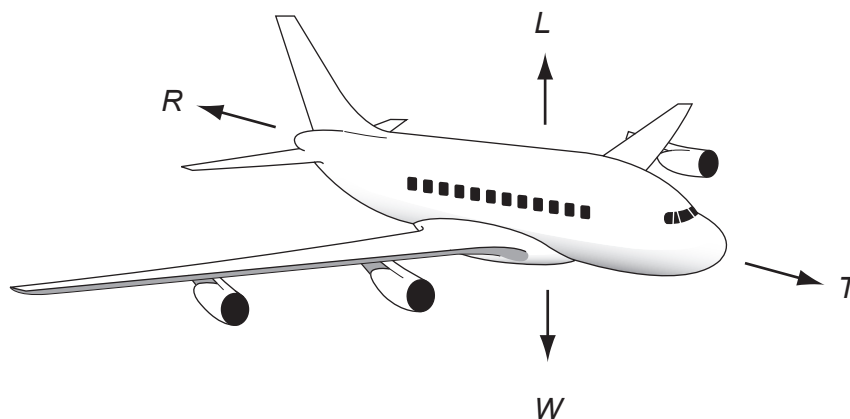

Which row is correct?

	vertical forces	horizontal forces
A	$L = W$	$T = R$
B	$L > W$	$T > R$
C	$L = W$	$T > R$
D	$L > W$	$T = R$

- 39 A person just supports a mass of 20 kg suspended from a rope.

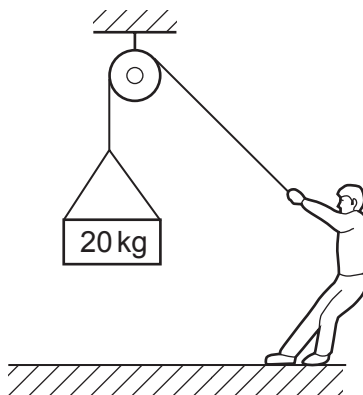

What is the resultant force acting on the mass?

- A** 0 N **B** 10 N **C** 20 N **D** 200 N
- 40 A particle P is moving in a horizontal circle about O. P moves at constant speed v .

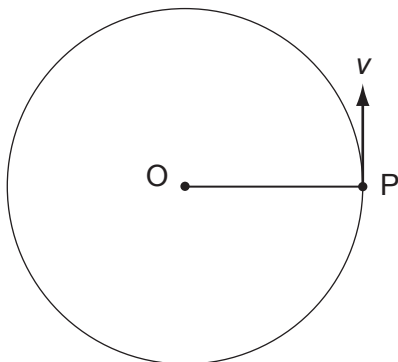

Which statement is true?

- A** A force of constant magnitude is acting in the same direction as v .
B A force of constant magnitude is acting towards O.
C The force on P varies in size as it moves around the circle.
D There is no resultant force acting on P.

- 41 A tractor pulls a trailer at a constant speed.

The tractor exerts a forward force of 1600 N on the trailer.

What is the force exerted by the trailer on the tractor?

- A 0 N
 - B 1600 N backwards
 - C 1600 N forwards
 - D 3200 N forwards
- 42 A turntable rotates at constant speed. A coin is placed on the turntable at P. The friction force between the coin and the turntable keeps the coin in the same position on the turntable.

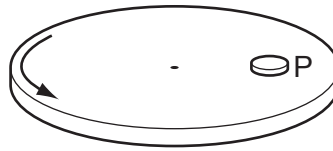

In which direction does the friction force act?

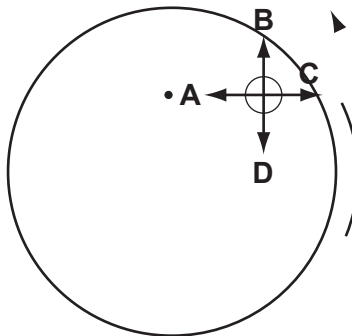

43 Two forces F_1 and F_2 act on an object O in the directions shown.

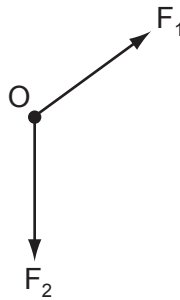

What is the direction of the resultant force?

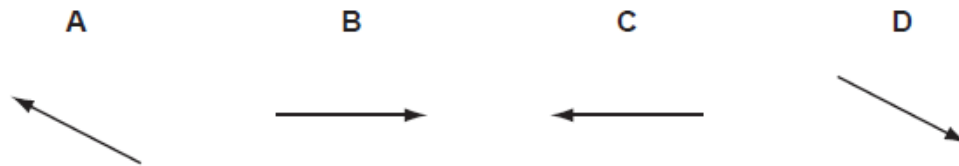

44 A wooden block is pushed across a table at constant speed.

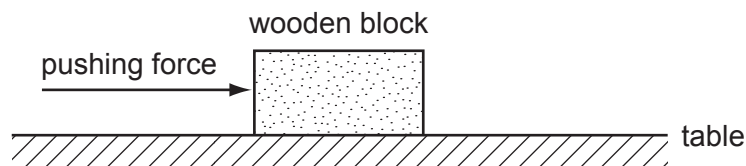

Which statement is correct?

- A The frictional force increases as the block moves at constant speed.
- B The frictional force is equal and opposite to the pushing force.
- C The frictional force is greater than the pushing force.
- D The frictional force is less than the pushing force.

45 What keeps an electron moving in a circle around the nucleus of an atom?

- A a gravitational force away from the nucleus
- B a gravitational force towards the nucleus
- C an electrostatic force away from the nucleus
- D an electrostatic force towards the nucleus

46 A car takes 1 hour to travel 100 km along a main road and then $\frac{1}{2}$ hour to travel 20 km along a side road.

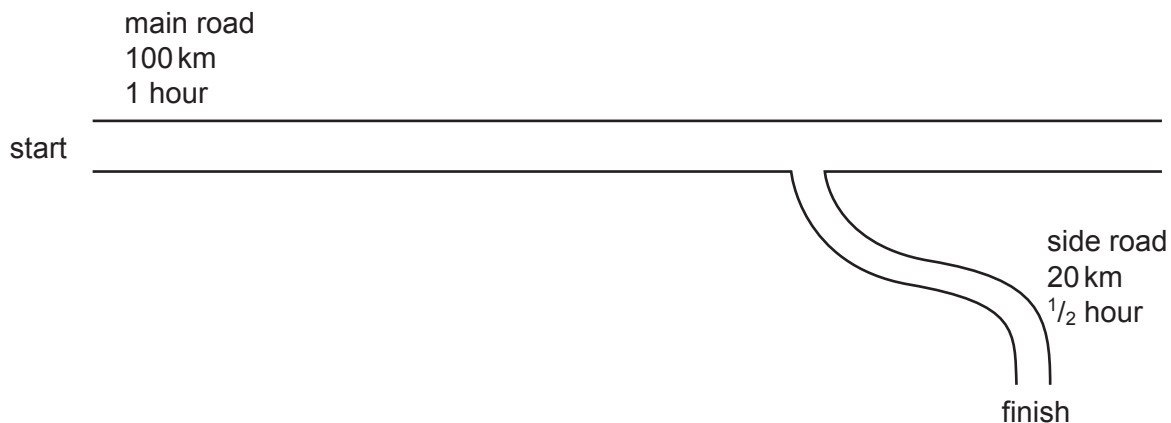

What is the average speed of the car for the whole journey?

- A 60 km/h B 70 km/h C 80 km/h D 100 km/h

47 How is the motion of a body affected by balanced and unbalanced forces acting on it?

	balanced forces	unbalanced forces
A	velocity changes	velocity changes
B	velocity changes	velocity constant
C	velocity constant	velocity changes
D	velocity constant	velocity constant

- 48 The diagram shows two objects on a beam balance in equilibrium.

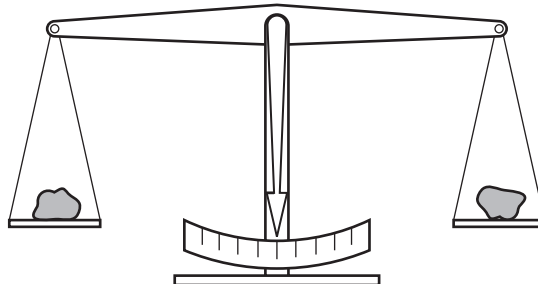

Which need not be the same?

- A the masses of the two objects
 - B the moments about the pivot of the two objects
 - C the volumes of the two objects
 - D the weights of the two objects
- 49 The propeller on a boat pushes water backwards with a force of 2000 N. The boat moves through the water against a total resistive force of 1800 N.

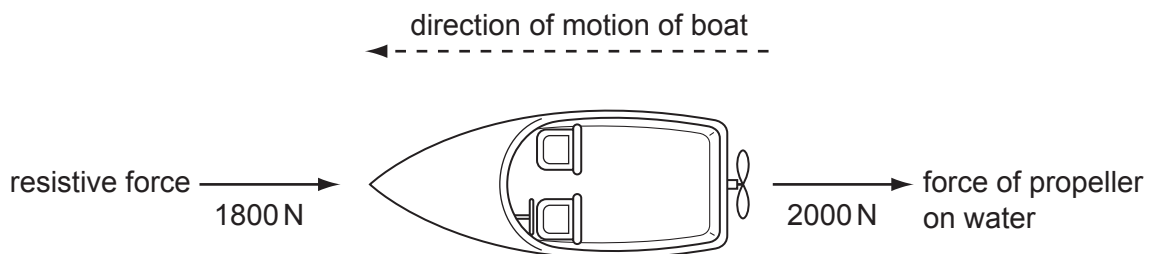

According to Newton's third law, what is the forward force on the propeller due to the water?

- A 3800 N
 - B 2000 N
 - C 1800 N
 - D 200 N
- 50 Forces of 30 N and 50 N act on the same body, but in different directions.

Which value could **not** be the resultant force on the body?

- A 10 N
- B 30 N
- C 50 N
- D 70 N

- 51 When a body moves across a rough surface, a frictional force is produced.

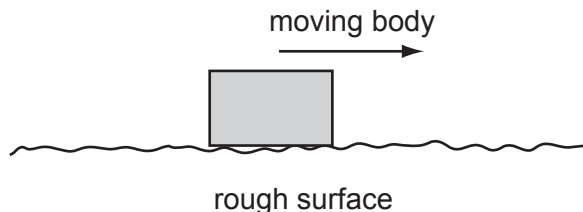

Which statement about this force is **always** true?

- A It acts in the direction of the motion.
 - B It is equal in value to the force producing the motion.
 - C It makes the body recoil in the opposite direction after stopping it.
 - D It opposes the motion across the surface.
- 52 A force of 20 N pushes an object of mass 5.0 kg along a rough horizontal surface where the frictional force is 5.0 N.

What is the acceleration of the object?

- A 1.0 m/s^2
 - B 2.0 m/s^2
 - C 3.0 m/s^2
 - D 4.0 m/s^2
- 53 Forces X and Y act on a block in the directions shown on the scale diagram.

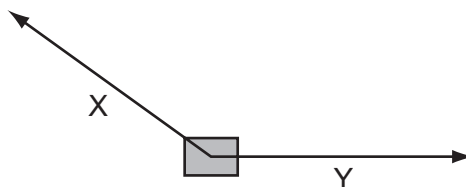

In which direction is the resultant force acting?

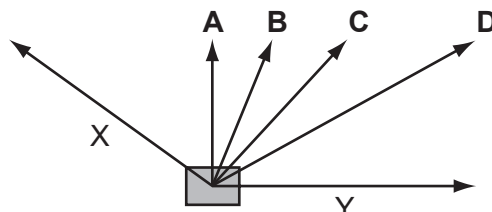

54 A body P moves in a circle around a point S. A force F keeps it moving in the circle.

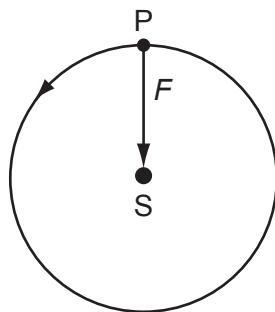

What happens if the force F suddenly disappears?

- A P moves directly towards S.
- B P moves in a circle closer to S.
- C P moves away from S in a curved path.
- D P goes off in a straight line.

55 Two forces act at right angles at a point O as shown.

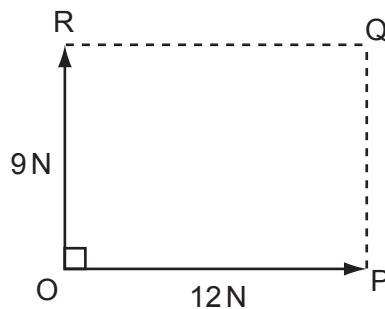

What is the resultant of the forces?

	magnitude	direction
A	15 N	OQ
B	15 N	PR
C	21 N	OQ
D	21 N	PR

56 Which is a statement of Newton's third law of motion?

- A Every force causes a reaction.
- B If there is no resultant force on a body then there is no acceleration.
- C The forces acting on a body are always equal and opposite.
- D To every action there is an equal but opposite reaction.

57 A car is travelling at constant speed along a road and drives over a large patch of oil. The driver applies the brakes to stop the car.

Compared to braking on a dry road, what may happen?

- A The car slows down more quickly because of the greater friction between the tyres and the road.
- B The car speeds up at first because of the reduced friction between the tyres and the road.
- C The car takes longer to slow down because of the reduced friction between the tyres and the road.
- D The car takes longer to slow down because the thinking distance of the driver is greater.

58 Forces of 3 N and 4 N are acting as shown in the diagram.

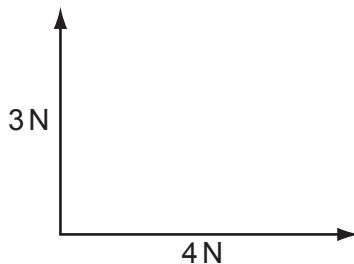

Which diagram may be used to find the resultant R of these two forces?

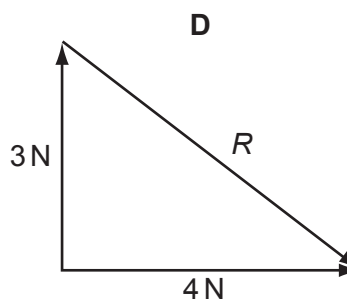
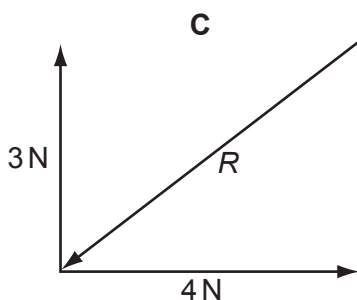
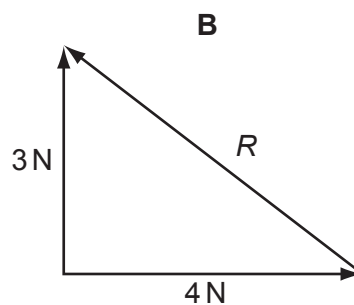
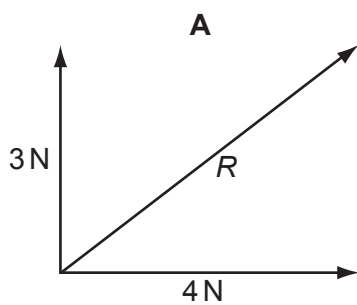

59 Trolley **X** and trolley **Y** are joined by a stretched spring. Trolley **X** has twice the mass of trolley **Y**.

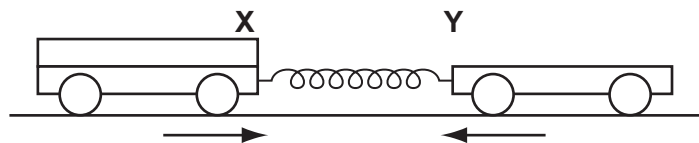

When the trolleys are released, the acceleration of **X** is 2 m/s^2 to the right.

What is the initial acceleration of trolley **Y** to the left?

- A** 1 m/s^2 **B** 2 m/s^2 **C** 3 m/s^2 **D** 4 m/s^2

60 The wheel of a moving car is driven by the engine. The car is accelerating in the direction shown.

In which direction does the frictional force act on the wheel?

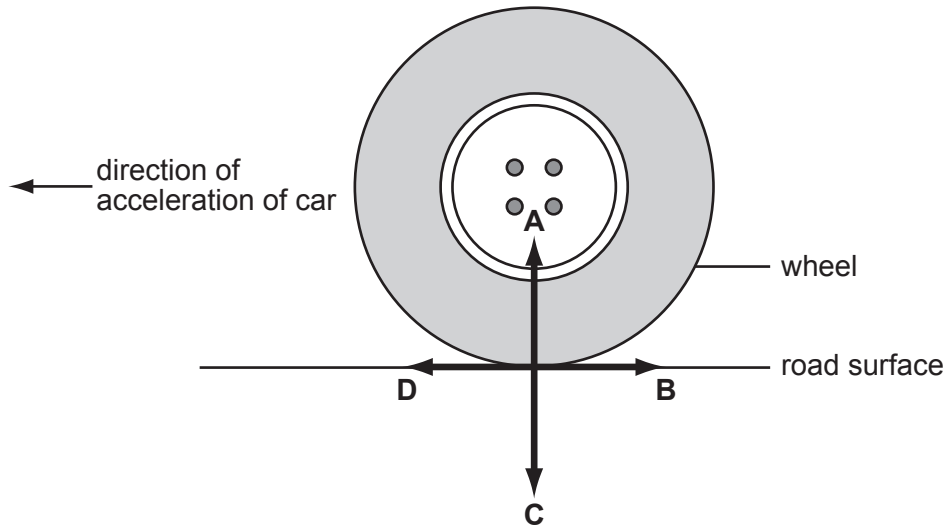

61 The diagram shows a cyclist leaning over in order to cycle around a corner.

Which force is necessary to maintain the motion around the corner?

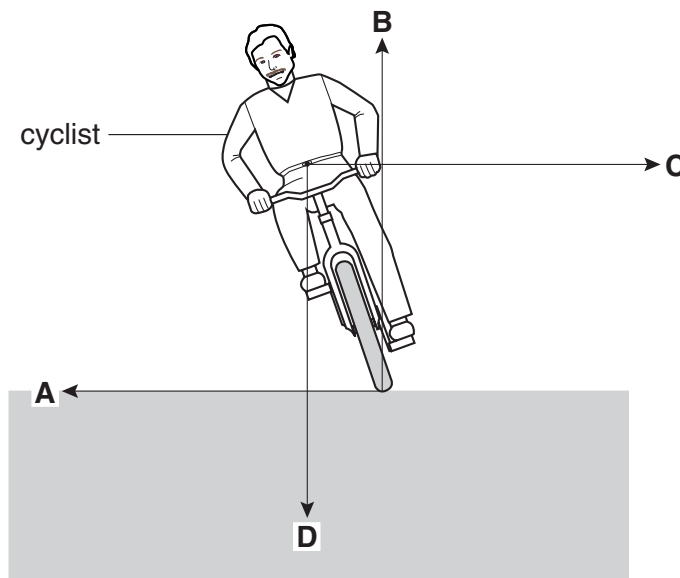

62 Which diagram correctly shows the addition of a 4 N and a 3 N force?

