

# QUESTION 1.

7



5 Five storage devices are described in the table below.

In column 2, name the storage device being described.

In columns 3, 4, or 5, tick (✓) to show the appropriate category of storage.

1	2	3	4	5
Description of storage device	Name of storage device	Category of storage		
		Primary	Secondary	Off-line
optical media which use one spiral track; red lasers are used to read and write data on the media surface; makes use of dual-layering technology to increase the storage capacity				
non-volatile memory chip; contents of the chip cannot be altered; it is often used to store the start up routines in a computer (e.g. the BIOS)				
optical media which use concentric tracks to store the data; this allows read and write operations to be carried out at the same time				
non-volatile memory device which uses NAND flash memories (which consist of millions of transistors wired in series on single circuit boards)				
optical media which use blue laser technology to read and write data on the media surface; it uses a single 1.1 mm polycarbonate disc				

[10]

# QUESTION 2.



9 Check digits are used to ensure the accuracy of entered data.

A 7-digit number has an extra digit on the right, called the check digit.

digit position:	1	2	3	4	5	6	7	8
digit:	-	-	-	-	-	-	-	-

↑  
check digit

The check digit is calculated as follows:

- each digit in the number is multiplied by its digit position
- the seven results are then added together
- this total is divided by 11
- the remainder gives the check digit (if the remainder = 10, the check digit is X)

(a) Calculate the check digit for the following number. Show all your working.

**4 2 4 1 5 0 8 ...**

.....

.....

.....

Check digit ..... [2]

(b) An operator has just keyed in the following number:

**3 2 4 0 0 4 5 X**

Circle below **correct** if the check digit is correct **OR incorrect** if the check digit is incorrect.

**correct                  incorrect**

Explain your answer.

.....

.....

.....

.....

[3]

# QUESTION 3.

7



7 (a)

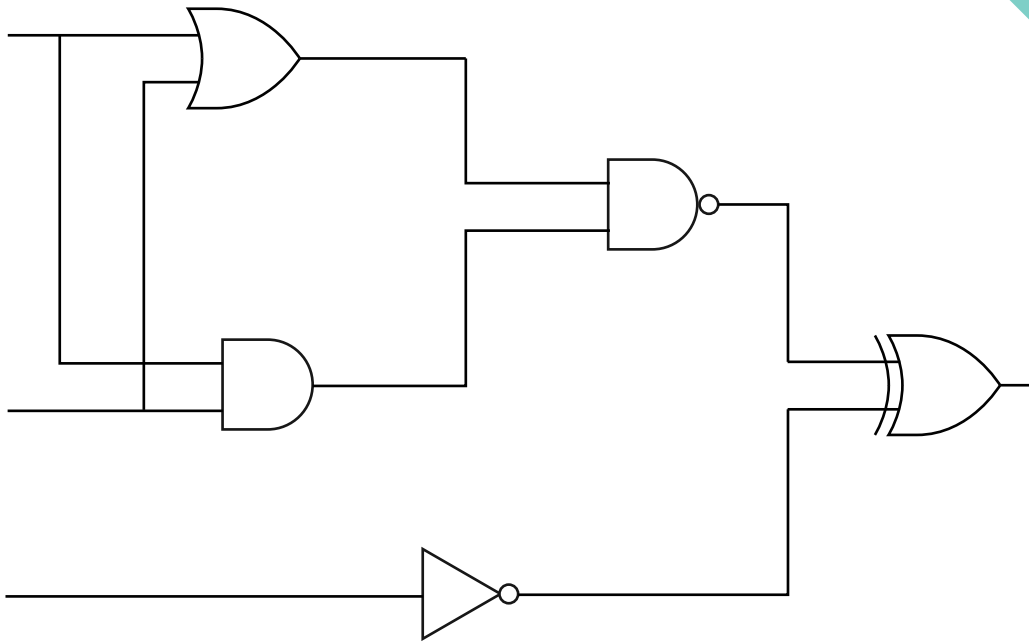

Complete the truth table for this logic circuit.

A	B	C	Working space	X
0	0	0		
0	0	1		
0	1	0		
0	1	1		
1	0	0		
1	0	1		
1	1	0		
1	1	1		

[4]

(b) Draw a logic circuit corresponding to the following logic statement:

$X = 1$  if  $((A \text{ is } 1 \text{ OR } B \text{ is } 1) \text{ AND } (A \text{ is } 1 \text{ AND } B \text{ is } 1)) \text{ OR } (C \text{ is NOT } 1)$

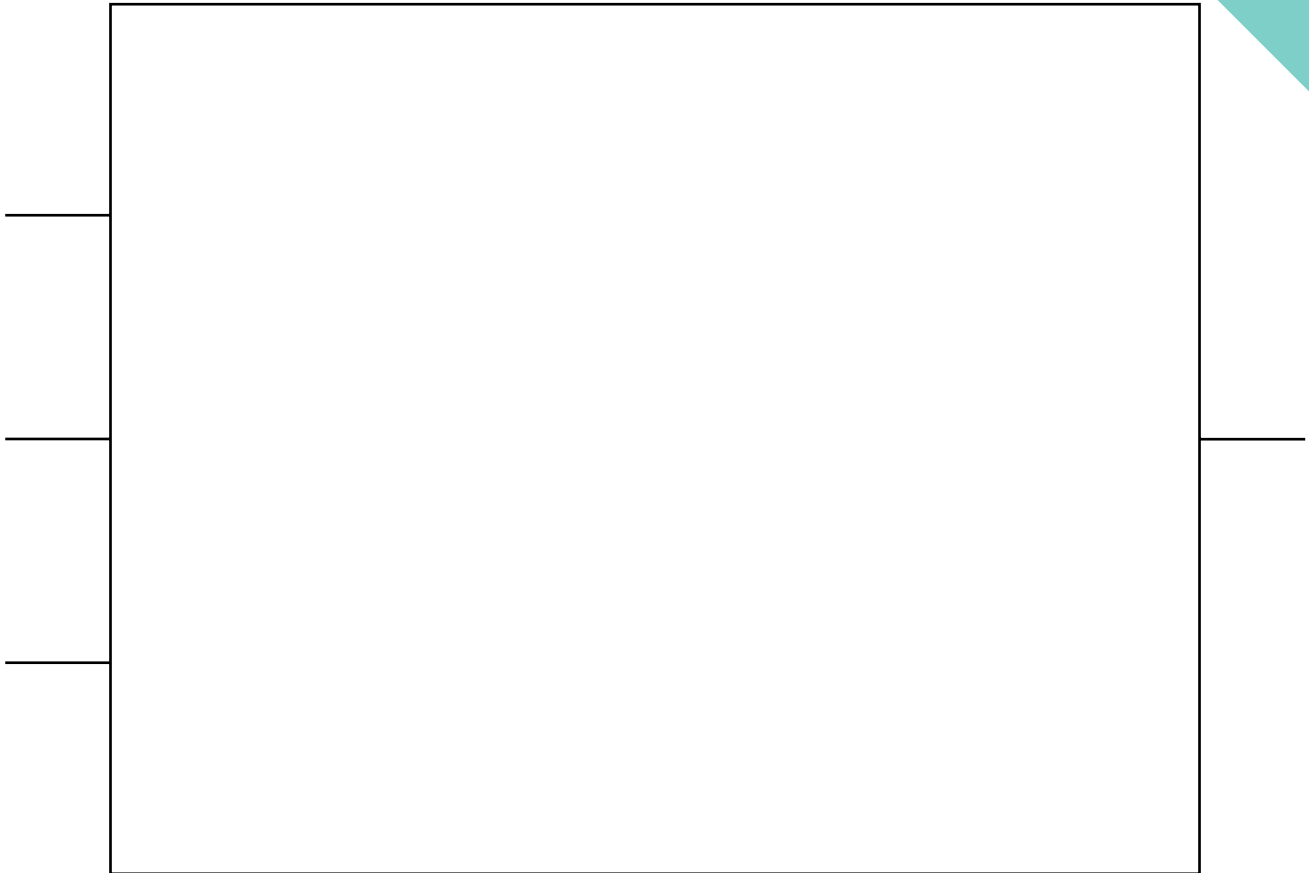

[5]





(c) Re-draw the following logic circuit using NAND gates only.

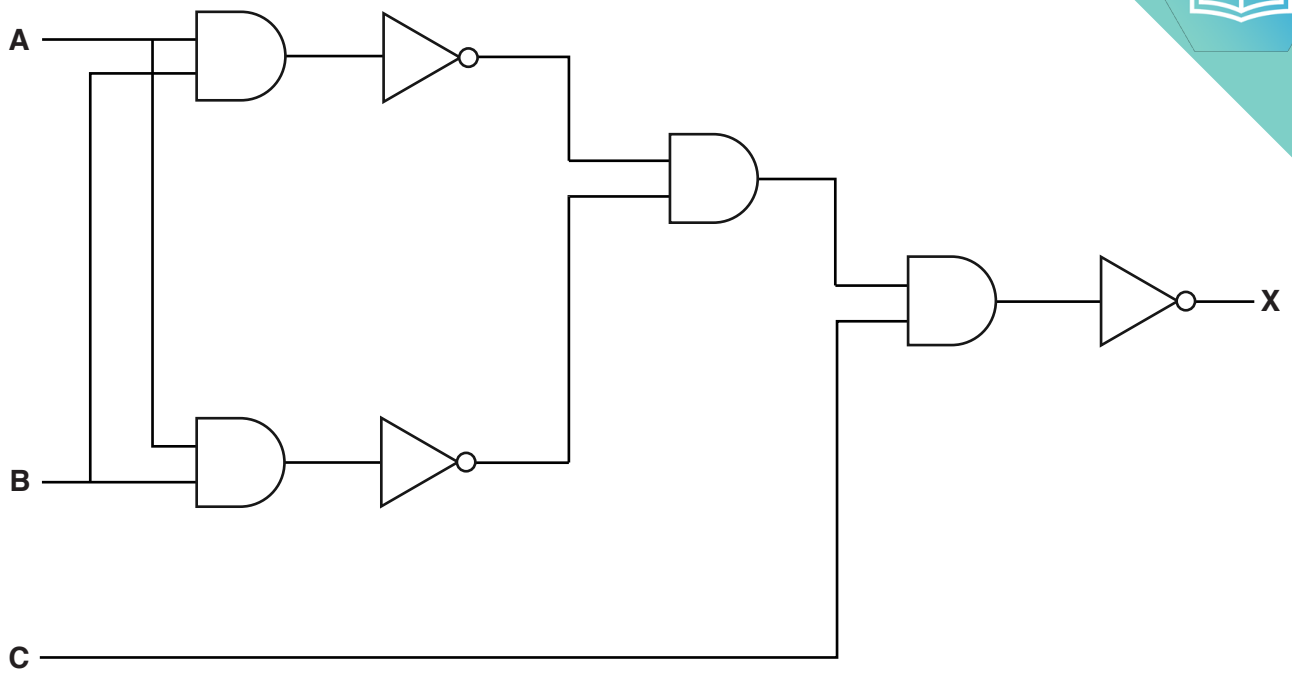

Logic circuit re-drawn:

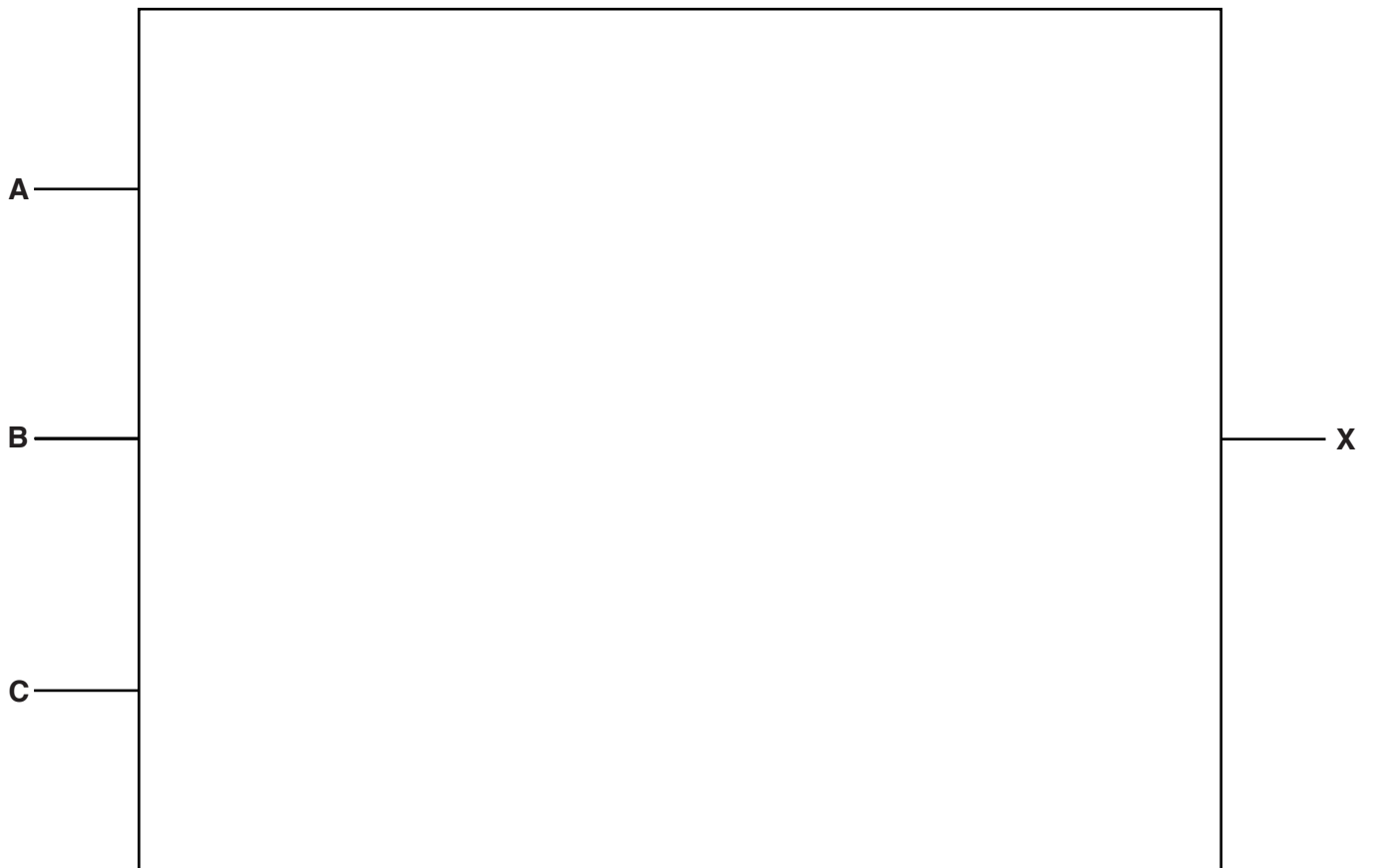

# QUESTION 4.



10 For this logic statement:

$$X = 1 \text{ if } (( A \text{ is } 1 \text{ AND } B \text{ is } 1 ) \text{ OR } ( B \text{ is } 1 \text{ AND } C \text{ is NOT } 1 ))$$

(a) Draw the logic circuit.

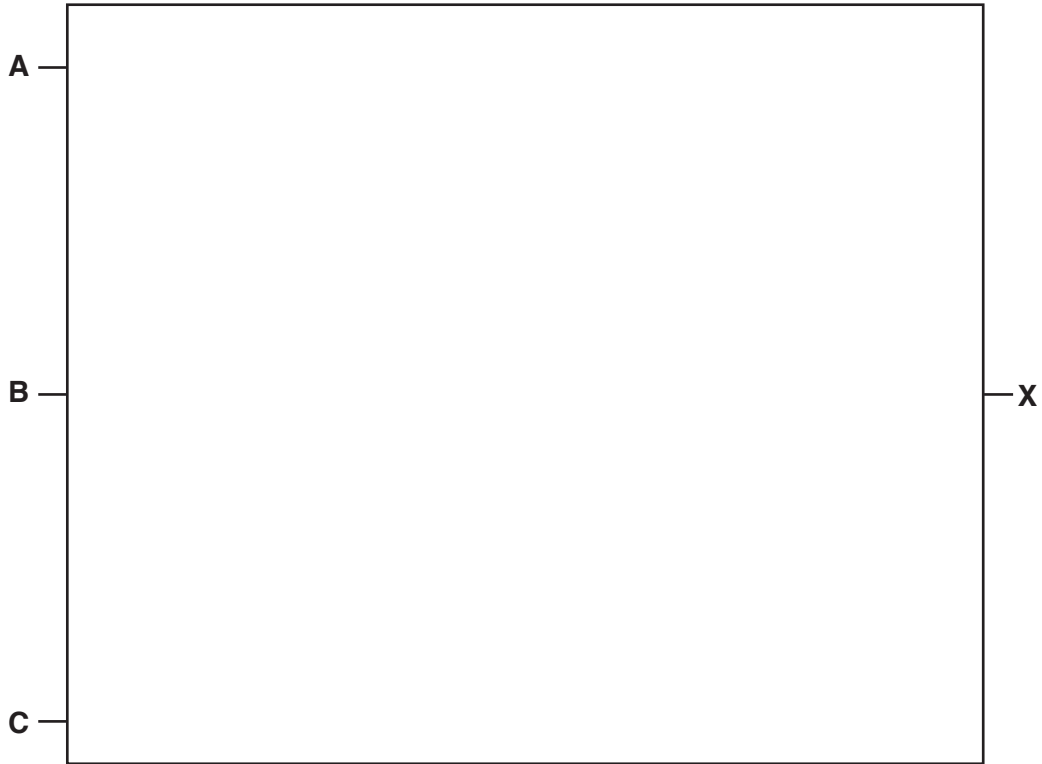

[4]

(b) Complete the truth table for the given logic statement.

A	B	C	Working space	X
0	0	0		
0	0	1		
0	1	0		
0	1	1		
1	0	0		
1	0	1		
1	1	0		
1	1	1		

[4]

## QUESTION 5.

7



7 Consider the logic statement:

$X = 1$  if  $((A \text{ is } 1 \text{ AND } B \text{ is NOT } 1) \text{ NAND } C \text{ is } 1) \text{ XOR } ((A \text{ is } 1 \text{ AND } C \text{ is } 1) \text{ OR } B \text{ is } 1)$

(a) Draw a logic circuit to represent the given logic statement.

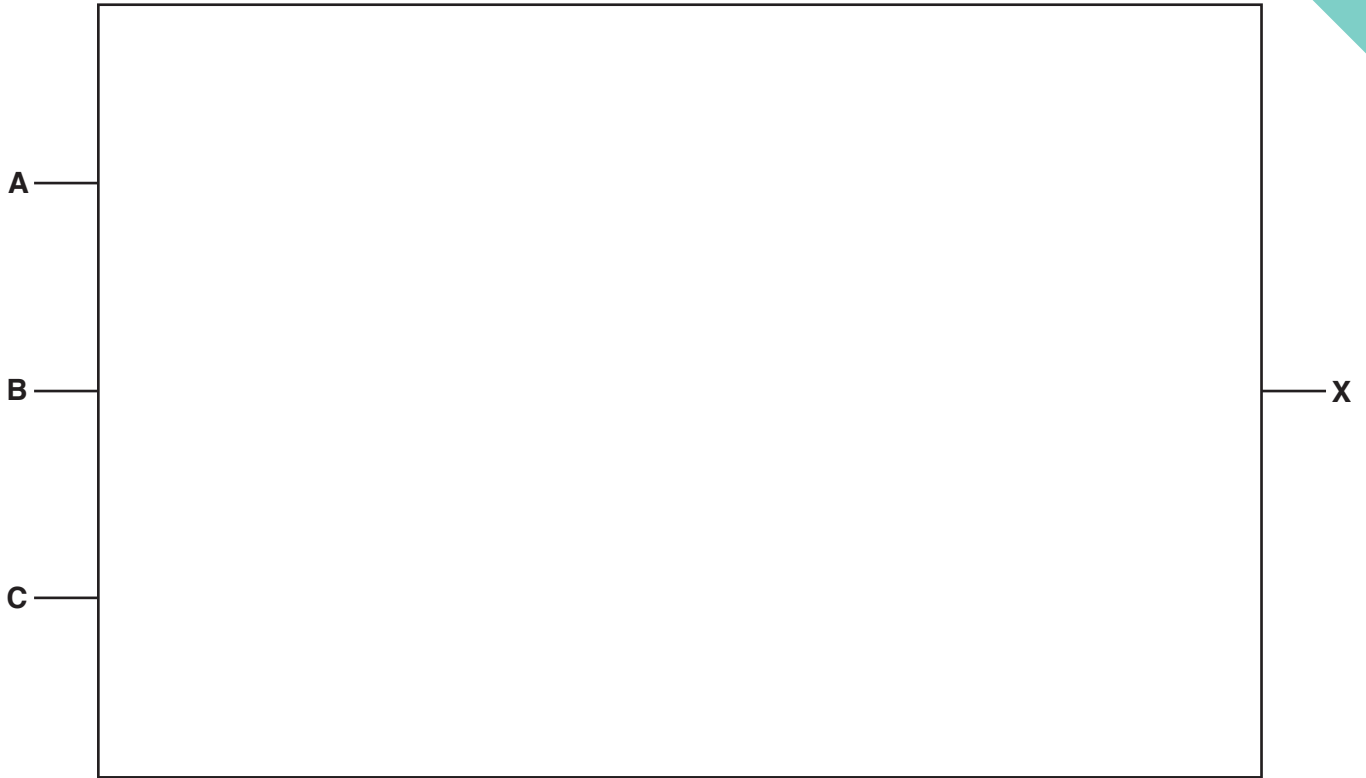

[6]

(b) Complete the truth table for the given logic statement.

A	B	C	Working space	X
0	0	0		
0	0	1		
0	1	0		
0	1	1		
1	0	0		
1	0	1		
1	1	0		
1	1	1		

[4]

# QUESTION 6.

8



8 A logic circuit is shown below.

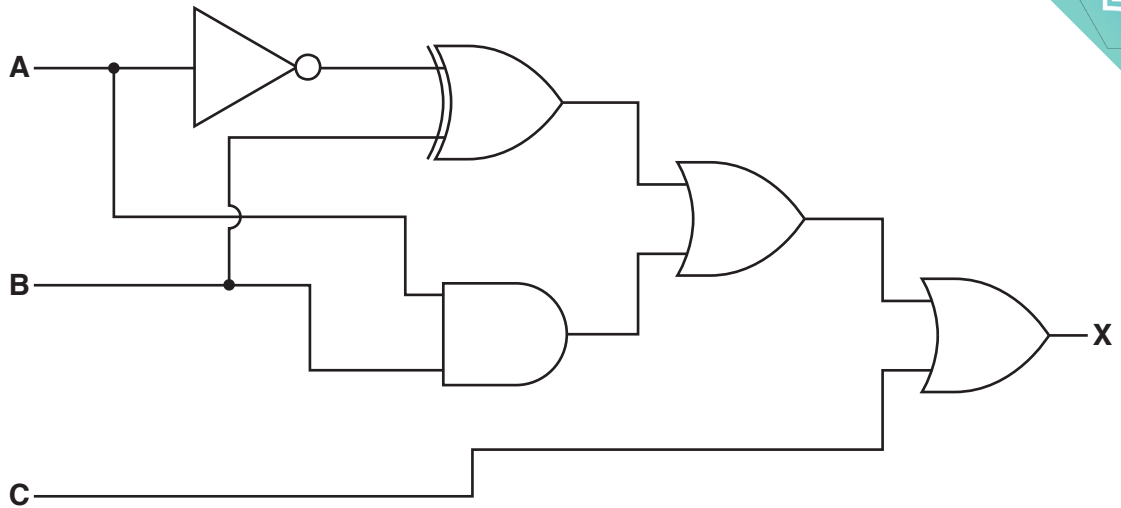

(a) Complete the truth table for the given logic circuit.

A	B	C	Working space	X
0	0	0		
0	0	1		
0	1	0		
0	1	1		
1	0	0		
1	0	1		
1	1	0		
1	1	1		

[4]

(b) Draw a logic circuit corresponding to this logic statement:

$X = 1$  if (A is NOT 1) OR ((B is 1 OR C is 1) AND (B is NOT 1 OR A is NOT 1))



# QUESTION 7.

4



4 (a) Identify the name **and** draw the **single** logic gate that can replace the given .

(i)

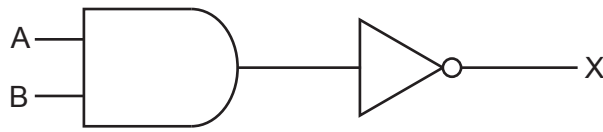

Name of gate: .....

Drawing of gate:

[2]

(ii)

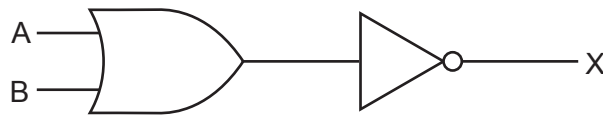

Name of gate: .....

Drawing of gate:

[2]

(b) Complete the truth table for the given logic statement:

$$X = (((A \text{ OR } C) \text{ AND } (\text{NOT } A \text{ AND } \text{NOT } C)) \text{ XOR } B)$$

A	B	C	Working space	X
0	0	0		
0	0	1		
0	1	0		
0	1	1		
1	0	0		
1	0	1		
1	1	0		
1	1	1		

[4]

# QUESTION 8.



6 Consider the given logic statement:

$$X = (((A \text{ XOR } B) \text{ AND } C) \text{ OR } \text{NOT } C)$$

(a) Draw a logic circuit to match the given logic statement.

All logic gates must have a maximum of **two** inputs. Do **not** attempt to simplify the logic statement.

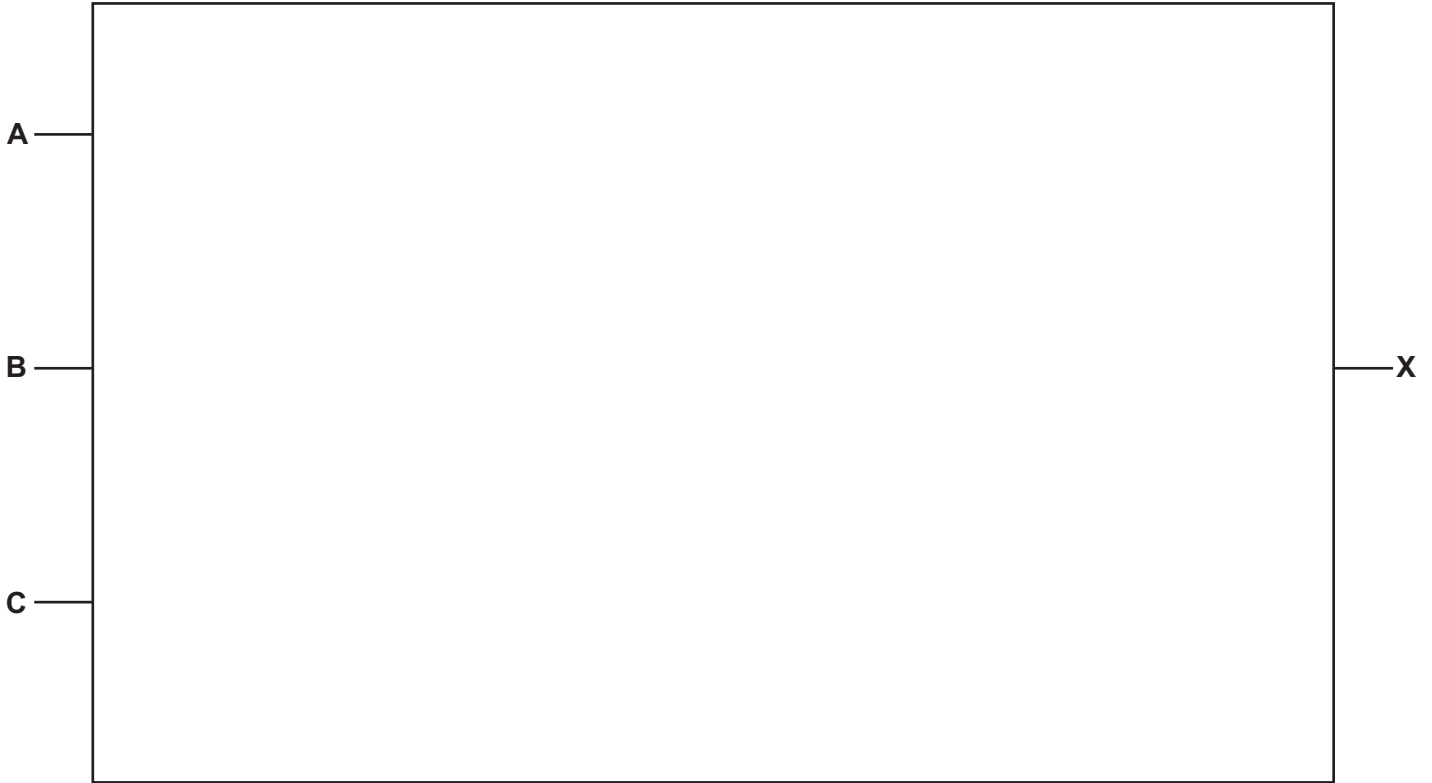

[4]

(b) Complete the truth table for the given logic statement.

A	B	C	Working space	X
0	0	0		
0	0	1		
0	1	0		
0	1	1		
1	0	0		
1	0	1		
1	1	0		
1	1	1		

[4]

# QUESTION 9.



4 (a) (i) Convert the following **two** hexadecimal numbers into binary:

**F A 7**  
**D 3 E**

**F A 7**

--	--	--	--

--	--	--	--

--	--	--	--

**D 3 E**

--	--	--	--

--	--	--	--

--	--	--	--

[4]

(ii) Now perform the AND (logic) operation on each corresponding pair of binary bits in the two numbers from **part (i)**.

--	--	--	--

--	--	--	--

--	--	--	--

[2]

(iii) Convert your answer in **part (ii)** into hexadecimal.

.....  
.....

[2]





(b) (i) The following code shows HTML ‘tag’ pairs on either side of the text s that each creates.

```

<font color " # F F 0 0 0 0 " > RED </font>
<font color " # 0 0 F F 0 0 " > GREEN </font>
<font color " # 0 0 0 0 F F " > BLUE </font>

<font color " #      X      " > YELLOW </font>
<font color " #      Y      " > MAGENTA </font>
<font color " #      Z      " > CYAN </font>

```

Yellow is a combination of red and green, magenta a combination of red and blue and cyan a combination of green and blue.

State what 6-digit hexadecimal values should replace X, Y and Z in the above code.

X .....

Y .....

Z .....

[3]

(ii) Describe how other colours, such as a darker shade of blue, are created.

.....  
.....  
.....

[2]

(c) 1A – 16 – C5 – 22 – FF – FF is an example of a MAC address.

(i) Identify what the first six and last six hexadecimal digits represent.

First six digits .....

.....  
.....

Last six digits .....

.....  
.....

[2]

(ii) State why MAC addresses are used.

.....  
.....

[1]

# QUESTION 10.

6



- 5 Three switches, A, B and C, each send values of 0 or 1 to a logic circuit. Value X is the output of the logic circuit.

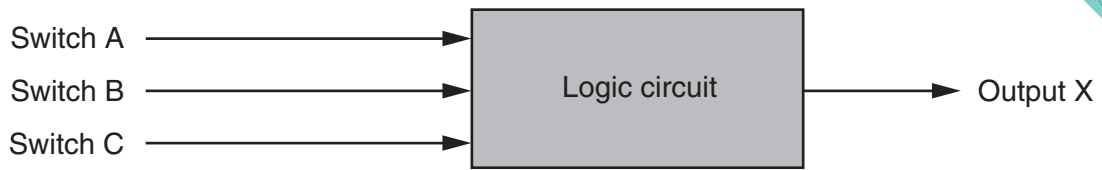

Output X has a value of 1 depending on the following conditions:

Switch A sends value 1 AND Switch B sends value 0

OR

Switch B sends value 1 AND Switch C sends value 0

- (a) Draw a logic circuit to represent the conditions above.

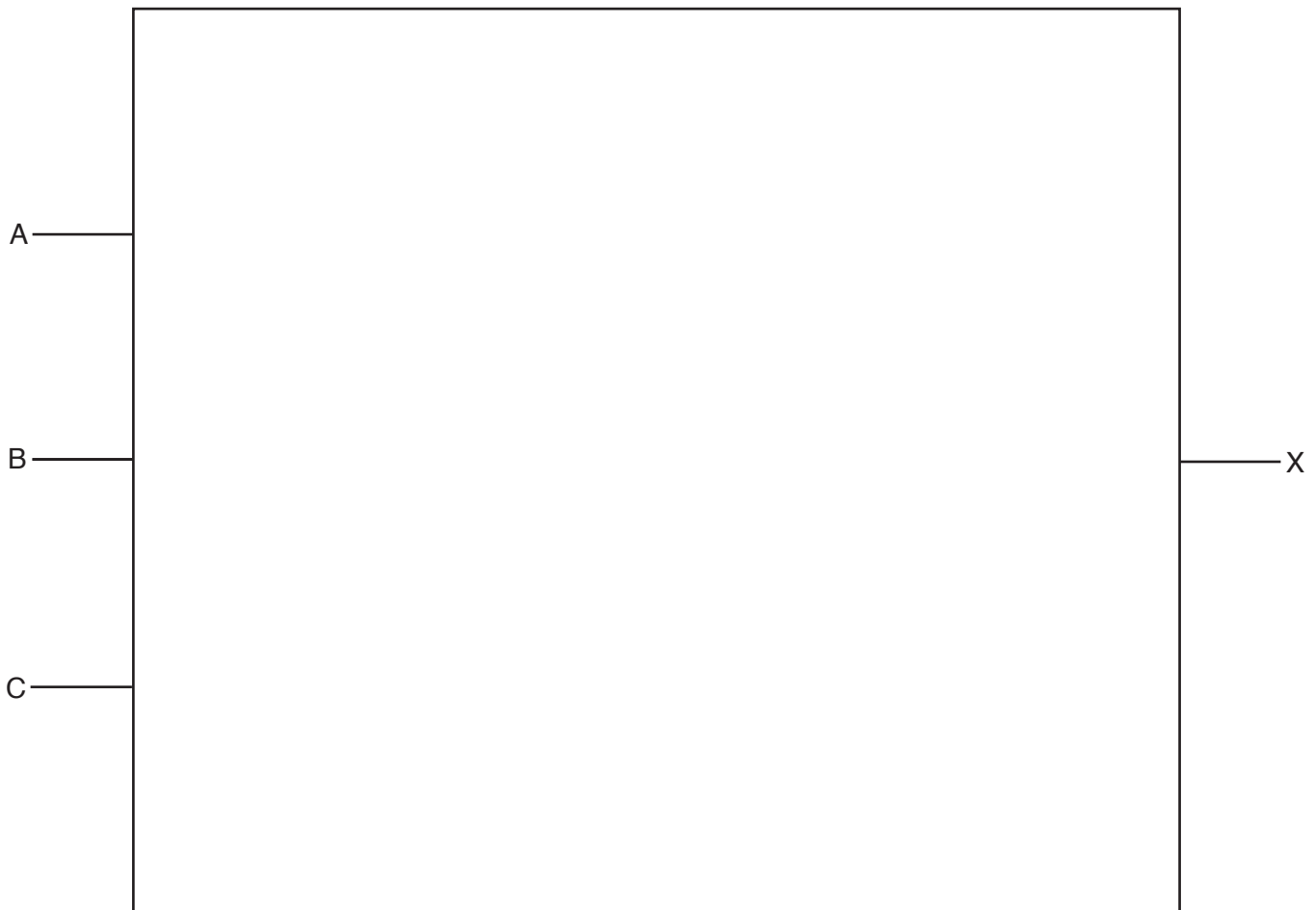

[5]



(b) Complete the truth table for the conditions given at the start of question 5.

A	B	C	Working space	X
0	0	0		
0	0	1		
0	1	0		
0	1	1		
1	0	0		
1	0	1		
1	1	0		
1	1	1		

[4]

(c) A microprocessor regularly samples the output, X. Each sample value is stored in an 8-bit register as shown below. One bit of this register is reserved as a parity bit.

Five consecutive output values of 1 indicate a fault condition.

Identify which of the following registers shows a fault condition.

Parity bit

1	1	1	1	1	0	0	1	Register Y
---	---	---	---	---	---	---	---	------------

0	1	0	1	1	1	1	1	Register Z
---	---	---	---	---	---	---	---	------------

Register .....[1]



(d) When eight bytes of data have been collected, they are transmitted to a computer system away. Parity checks are carried out to identify if the data has been transmitted correctly. The computer system uses **even parity** and column 1 is the parity bit.

The eight bytes of data are sent together with a ninth parity byte:

	parity bit	column 2	column 3	column 4	column 5	column 6	column 7	column 8
byte 1	1	0	0	0	0	1	0	0
byte 2	1	1	1	1	0	0	1	1
byte 3	0	1	0	0	1	0	0	0
byte 4	0	1	1	1	0	0	0	1
byte 5	1	0	0	0	1	1	1	1
byte 6	0	0	0	0	0	0	0	0
byte 7	1	1	1	0	1	0	0	0
byte 8	1	0	0	0	1	1	1	0
parity byte	1	0	1	1	0	1	1	1

(i) Identify which of the eight bytes contains an error.

byte .....[1]

(ii) Identify which column contains an error.

column .....[1]

(iii) The incorrect bit is indicated where the byte number and column cross.

Give the corrected byte.

--	--	--	--	--	--	--	--

[1]

(iv) Calculate the denary value of the corrected byte.

.....  
 .....[1]

(v) Considering the fault condition given in **part (c)**, explain why it is very important that the incorrect bit is located and corrected.

.....  
 .....  
 .....  
 .....[2]

# QUESTION 11.



7 (a) Complete the truth tables and name the single logic gate that could replace e

(i)

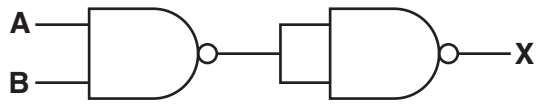

A	B	Working space	
0	0		
0	1		
1	0		
1	1		

Single logic gate .....[3]

(ii)

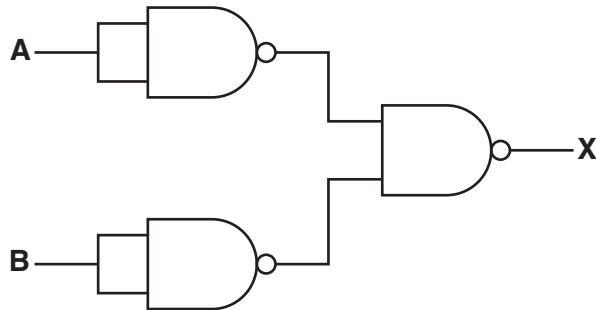

A	B	Working space	X
0	0		
0	1		
1	0		
1	1		

Single logic gate .....[3]



(b) (i) Draw a logic circuit to represent the following logic statement:

$$X = 1 \text{ if } (A = 1 \text{ AND } B = 1) \text{ OR } ((B = \text{NOT } 1) \text{ AND } C = 1)$$

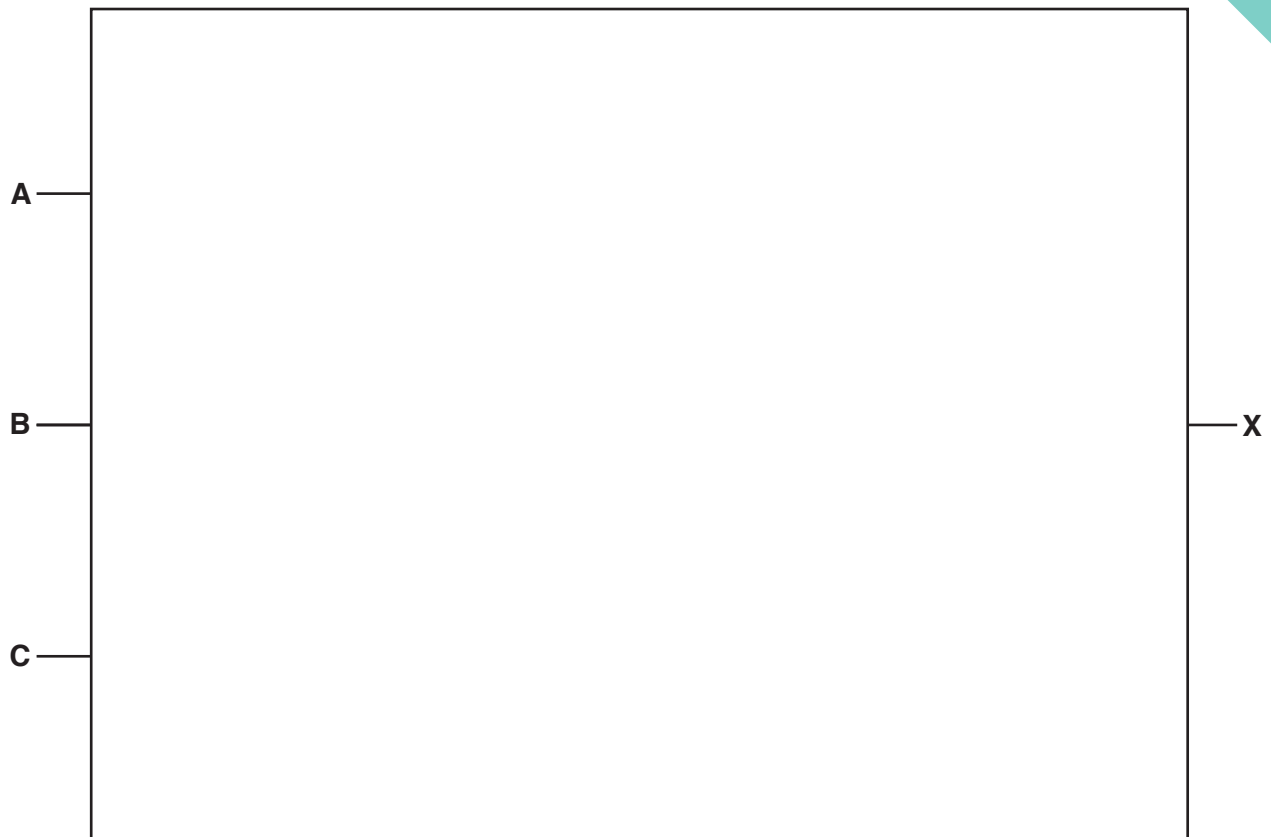

[4]

(ii) Complete the truth table for the logic statement in **part (b)(i)**.

A	B	C	Working space	X
0	0	0		
0	0	1		
0	1	0		
0	1	1		
1	0	0		
1	0	1		
1	1	0		
1	1	1		

[4]



# QUESTION 13.



6 (a) Many programmers write computer programs in high-level languages. The programs must be translated into machine code to be read by the computer.

State **two** types of translator that can be used.

Translator 1 .....

Translator 2 ..... [2]

(b) Explain **two** reasons why a computer programmer may choose to write a program in a high-level language, rather than a low-level language.

Reason 1 .....

.....

.....

.....

Reason 2 .....

.....

.....

..... [4]

(c) **Three** examples of computer code are given in the table.

Tick (✓) to show whether each example of computer code is **High-level language**, **Assembly language** or **Machine code**.

Computer code	High-level language (✓)	Assembly language (✓)	Machine code (✓)
10110111 11001100 01011100			
FOR X = 1 TO 10 PRINT X NEXT X			
INP X STA X LDA Y			

[3]



# QUESTION 14.



7 A factory manufactures plastic pipes. It uses logic circuits to control the manufacture.

(a) Consider the logic gate:

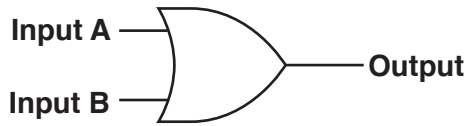

Complete the truth table for this logic gate.

Input A	Input B	Output
0	0	
0	1	
1	0	
1	1	

[1]

(b) Consider the truth table:

Input A	Input B	Output
0	0	0
0	1	1
1	0	1
1	1	0

State the **single** logic gate that produces the given output.

..... [1]



- (c) Plastic pipes of various sizes are manufactured by heating the plastic and using a manufacturing system. The manufacturing system uses sensors to measure the pressure (P), temperature (T) and speed (S) of production.

The inputs to the manufacturing system are:

Input	Binary value	Condition
P	1	pressure is > 5 bar
	0	pressure is <= 5 bar
T	1	temperature is > 200 degrees Celsius
	0	temperature is <= 200 degrees Celsius
S	1	speed is > 1 metre per second
	0	speed is <= 1 metre per second

The system will sound an alarm (X) when certain conditions are detected.

The alarm will sound when:

Temperature is > 200 degrees Celsius and the pressure is <= 5 bar  
**or**  
 Speed is > 1 metre per second and Temperature is <= 200 degrees Celsius

Draw a logic circuit to represent the above alarm system.

Logic gates used must have a maximum of **two** inputs.

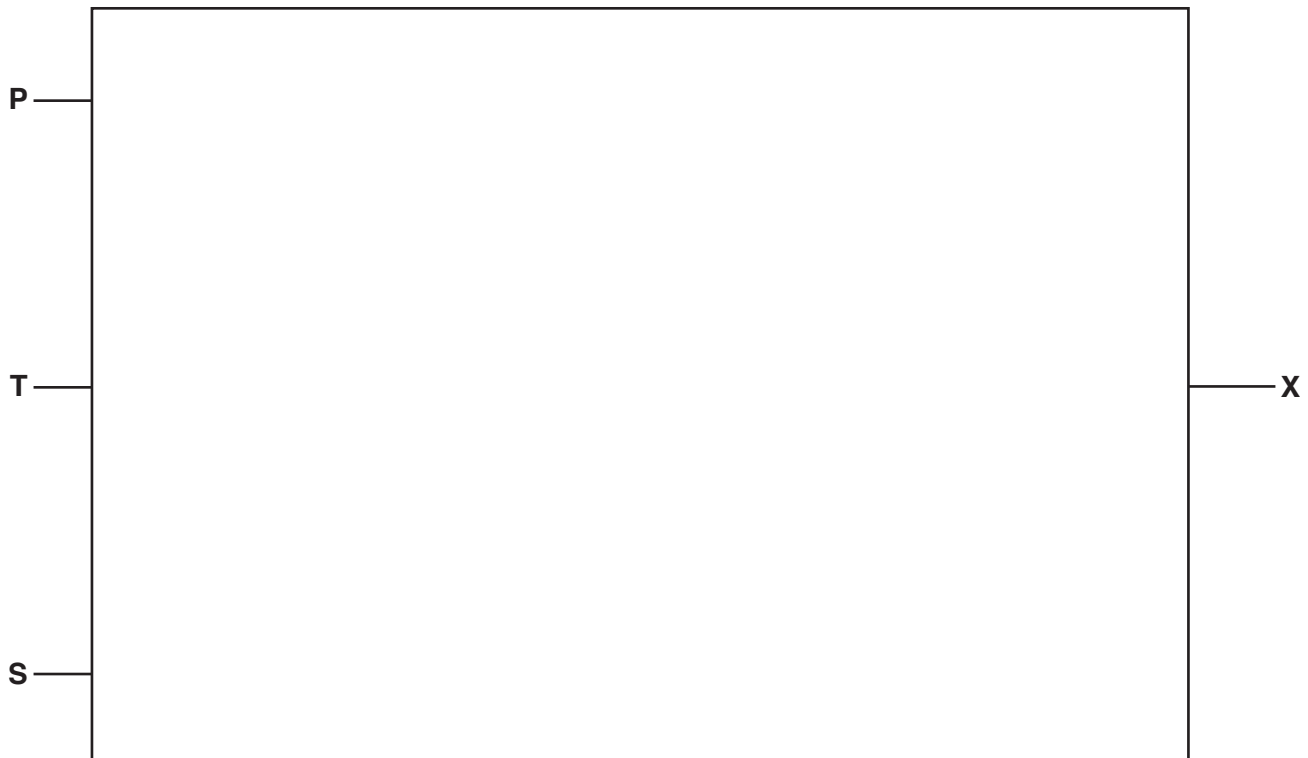

11

(d) Give **two** benefits of using sensors to monitor the manufacture of plastic pipes.

- 1 .....
- .....
- 2 .....



# QUESTION 15.



8 Consider the logic circuit:

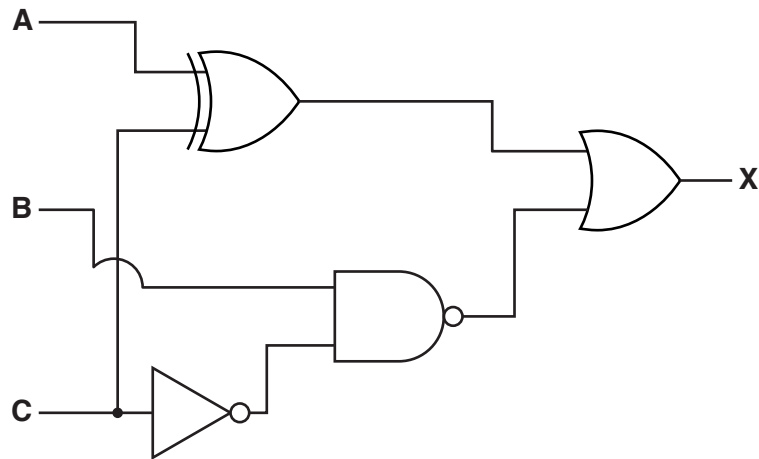

(a) Write a logic statement to match the given logic circuit.

..... [3]

(b) Complete the truth table for the given logic circuit.

A	B	C	Working space	X
0	0	0		
0	0	1		
0	1	0		
0	1	1		
1	0	0		
1	0	1		
1	1	0		
1	1	1		

[4]

# QUESTION 16.



4 A factory that manufactures cleaning products has a system that monitors conditions during the manufacturing process.

The inputs to the system are:

Input	Binary value	Condition
<b>A</b>	1	pH > 7
	0	pH ≤ 7
<b>T</b>	1	Temperature < 35 °C
	0	Temperature ≥ 35 °C
<b>P</b>	1	Pressure ≥ 80 %
	0	Pressure < 80 %

(a) The system will sound an alarm (**X**) when certain conditions are detected.

The alarm will sound when:

- The pressure ≥ 80 % and the temperature ≥ 35 °C

or

- The temperature < 35 °C and the pH > 7

Draw a logic circuit to represent the alarm system in the factory. Each logic gate must have a maximum of two inputs.

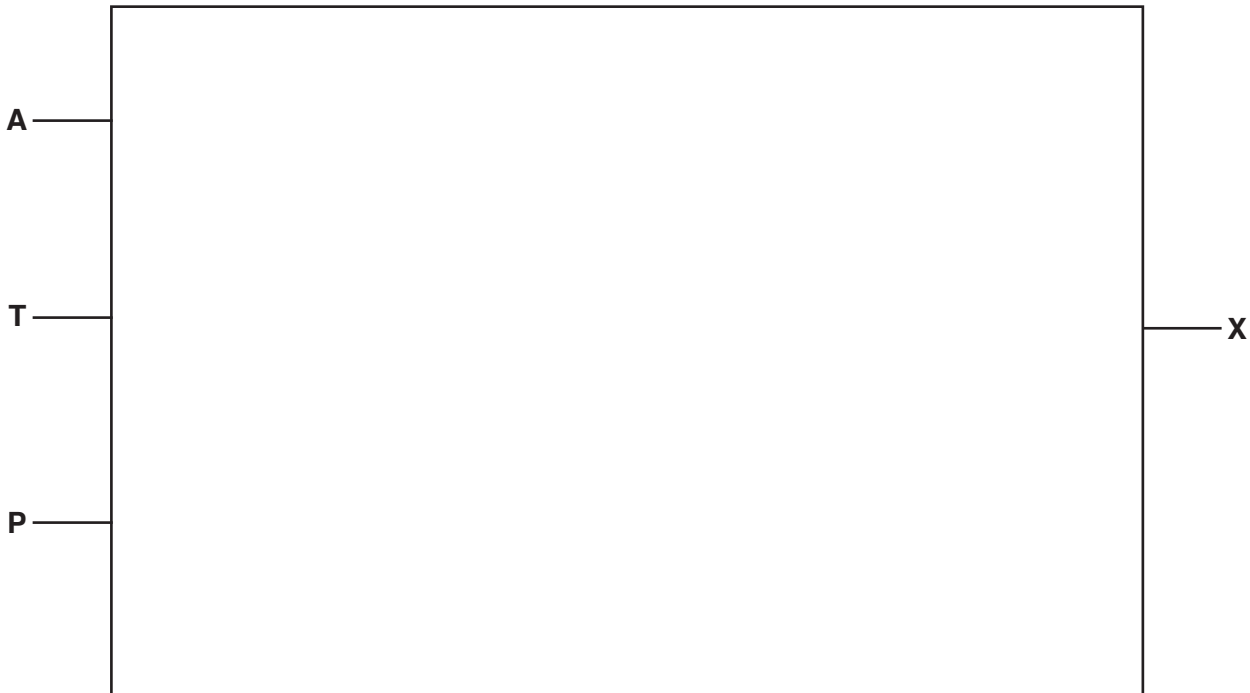



(b) Complete the truth table for the given logic problem.

A	T	P	Working space	X
0	0	0		
0	0	1		
0	1	0		
0	1	1		
1	0	0		
1	0	1		
1	1	0		
1	1	1		

[4]

(c) A sensor and a microprocessor are used to monitor the pH of the cleaning products. The system records each reading that is taken. If the reading is greater than 7 a warning message is displayed on a monitor.

Explain how the sensor and microprocessor are used in the system.

.....

.....

.....

.....

.....

.....

.....

.....

.....

.....

.....

.....

.....

.....

.....

.....

.....

.....

.....

[6]