

Candidate Number	Candidate Name										
<table border="1" style="width: 100%; height: 20px;"> <tr> <td style="width: 12.5%;"></td> <td style="width: 12.5%;"></td> <td style="width: 12.5%;"></td> <td style="width: 12.5%;"></td> <td style="width: 12.5%;"></td> <td style="width: 12.5%;"></td> <td style="width: 12.5%;"></td> <td style="width: 12.5%;"></td> <td style="width: 12.5%;"></td> <td style="width: 12.5%;"></td> </tr> </table>											

# JUNIOR SECONDARY CERTIFICATE

**NEEDLEWORK AND CLOTHING**

**1401/1**

PAPER 1

2 hour 15 minutes

Marks 130

**2017**

No Additional Materials.

## INSTRUCTIONS AND INFORMATION TO CANDIDATES

- Candidates answer on the Question Paper in the spaces provided.
- Write your Candidate Number and Name in the spaces at the top of this page and on all separate answer sheets used.
- Write in dark blue or black pen.
- Do not use correction fluid.
- You may use a soft pencil for any rough work, diagrams or graphs.
- Answer **all** questions.
- The number of marks is given in brackets [ ] at the end of each question or part question.

For Examiner's Use	
<b>Section A</b>	
<b>Section B</b>	
<b>Total</b>	

<i>Marker</i>	
<i>Checker</i>	

This document consists of **16** printed pages.



**Republic of Namibia**  
**MINISTRY OF EDUCATION, ARTS AND CULTURE**

## SECTION A

For Examiner's  
Use

- 1 The pattern envelope shows the front and back of a pattern on page 3 and 4. Study the illustrations and pattern information carefully.

**(a) Complete**

The loose fitting top has a collar with a **(i)** .....

**(ii)** ..... seams and short

**(iii)** ..... sleeves.

The hems are **(iv)** .....

Top A, B, C and D have **(v)** ..... variations.

Top B and D have **(vi)** ..... and Top D, E have

side **(viii)** .....

[7]

- (b) Determine the correct pattern size for a person with figure measurements:**

Bust = 78 cm, Waist = 59 cm, Hip = 83 cm

.....

[1]

- (c) How much fabric, 115 cm wide is needed to make:**

**(i)** Top D, size 22

.....  
.....

[2]

**(ii)** Top C, size 6

.....  
.....

[2]

**(iii)** Top B, size 16

.....  
.....

[2]

**(iv)** Top A, size 12

.....  
.....

[2]

Pattern envelope front

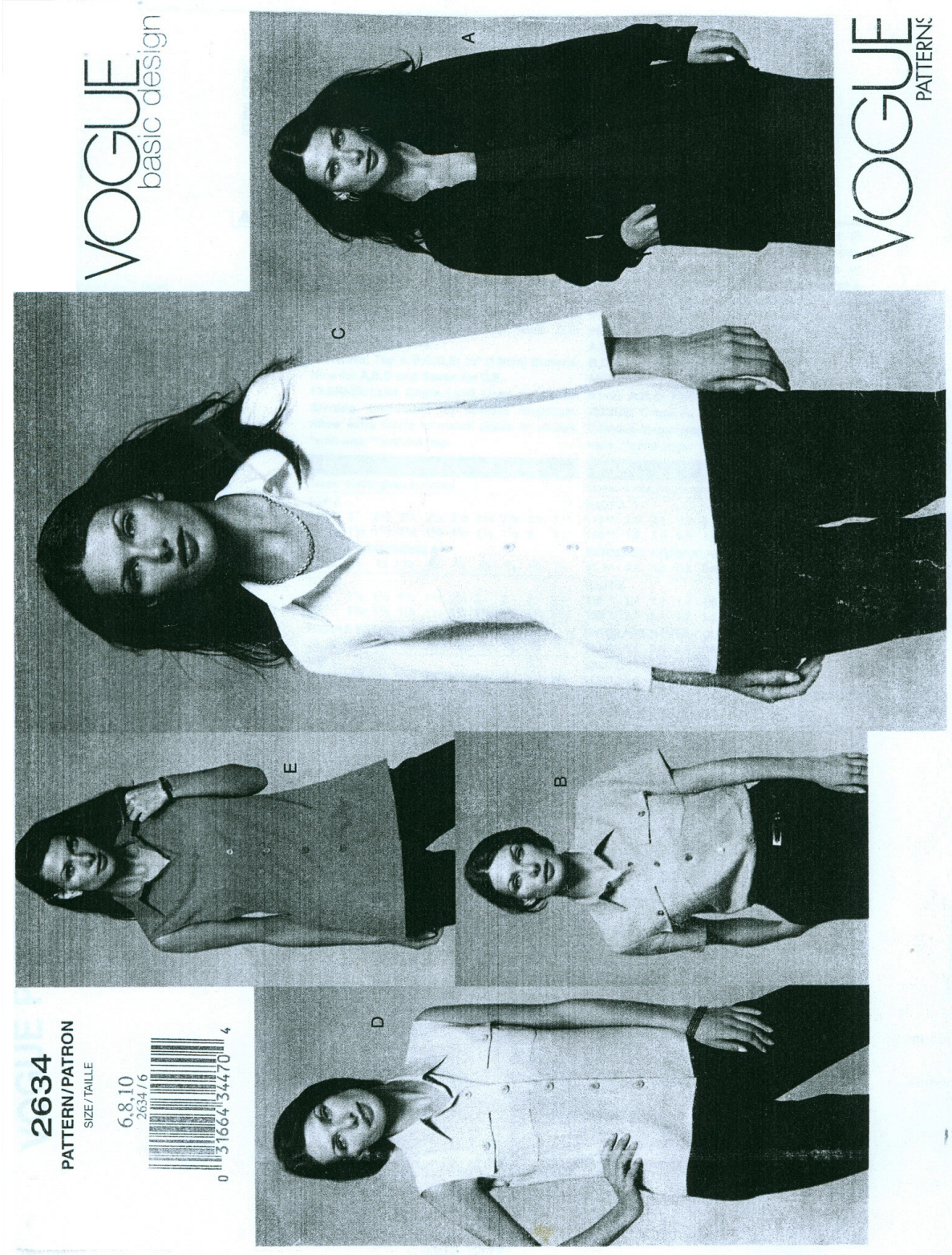

Pattern envelope back

**VOGUE PATTERN SERVICE**  
 NEW YORK • LONDON • PARIS • MILAN • TORONTO • SYDNEY • WWW.VOGUEPATTERNS.COM  
 120 BROADWAY, NEW YORK, 10271 © 2002 BUTTERICK COMPANY. ALL RIGHTS RESERVED.  
 THIS PATTERN IS TO BE USED FOR HOME SEWING ONLY • CE PATRON EST CONÇU POUR L'USAGE EXCLUSIF DE LA COUTURIÈRE AU FOYER

**2634**  
 SIZE/TAILLE

SIZE/TAILLE	6	8	10	12	14	16	18	20	22	24
Bust	30½	31½	32½	34	36	38	40	42	44	46
Waist	23	24	25	26½	28	30	32	34	37	39
Hip	32½	33½	34½	36	38	40	42	44	46	48
T. de poitrine	78	80	83	87	92	97	102	107	112	117
T. de taille	58	61	64	67	71	76	81	87	94	99
T. de hanches	83	85	88	92	97	102	107	112	117	122

**VOGUE PATTERNS**



**MISSES'/MISSES' PETITE TOP** Loose-fitting top (three-lengths) has collar, collar band, slightly forward shoulder seams and short or below-elbow sleeves with stitched hems or long, two-piece effect sleeves with pleats/button cuffs. Narrow hem. A: shaped hemline. A,B,C,D: pocket variations. B,D: flaps. D,E: sleeveless, side slits.

**NOTIONS:** Top A,B,C,D,E: ½" (13mm) Buttons: Nine for A,B,D and Seven for C,E.

**FABRICS:** Lt.wt. Crepe, Lt.wt. Linen and Cotton Shirting. Unsuitable for obvious diagonals. Allow extra fabric to match plaids or stripes. \*with nap. \*\*without nap.

SIZE	(6	8	10)	(12	14	16)	(18	20	22)
------	----	---	-----	-----	----	-----	-----	----	-----

Fabric widths given in inches.

**TOP A**

45**	2	2¼	2¼	2½	2½	2¾	2¾	2¾	3
60**	1⅝	1⅝	1⅝	1¾	1¾	1⅞	1⅞	2	2

**FUSIBLE INTERFACING A**

20, 24	⅝	⅝	⅝	⅝	⅝	⅝	⅝	¾	¾
--------	---	---	---	---	---	---	---	---	---

**TOP B**

45**	1¼	1½	1½	1¾	1¾	2	2	2	2¼
60**	1⅞	1⅞	1¼	1¼	1¼	1⅞	1⅞	1⅞	1⅞

**FUSIBLE INTERFACING B**

20, 24	⅝	⅝	⅝	⅝	⅝	⅝	⅝	¾	¾
--------	---	---	---	---	---	---	---	---	---

**TOP C**

45**	1½	1¾	1¾	2	2	2¼	2¼	2¼	2½
60**	1¾	1¾	1¾	1¾	1¾	1¾	1½	1½	1½

**FUSIBLE INTERFACING C**

20, 24	¼	⅝	⅝	⅝	⅝	⅝	⅝	¾	¾
--------	---	---	---	---	---	---	---	---	---

**TOP D**

45**	1⅞	1⅞	1⅞	1⅞	1⅞	1⅞	1⅞	1⅞	2
60**	1⅞	1⅞	1⅞	1⅞	1¼	1¼	1¼	1¼	1¼

**FUSIBLE INTERFACING D**

20, 24	⅝	⅝	⅝	⅝	⅝	⅝	⅝	¾	¾
--------	---	---	---	---	---	---	---	---	---

**TOP E**

45**	1⅞	1⅞	1⅞	1⅞	1⅞	2⅞	2¼	2¼	2¼
60**	1⅞	1⅞	1¼	1¼	1¾	1¾	1¾	1¾	1¾

**FUSIBLE INTERFACING E**

20, 24	¼	⅝	⅝	⅝	⅝	⅝	⅝	¾	¾
--------	---	---	---	---	---	---	---	---	---

**WIDTHS Lower edge**

A	40	41	42	43	45	47	49	51	53
B,C,D,E	37	38	39	40	42	44	46	48	50

**LENGTHS Finished back from base of your neck**

A	30½	30¾	31	31¼	31½	31¾	32	32¼	32½
B,C,D	23	23¼	23½	23¾	24	24¼	24½	24¾	25
E	27	27¼	27½	27¾	28	28¼	28½	28¾	29

**HAUT (J. femme/Petite J. femme)** Haut (3 longueurs), ample, avec col sur pied-de-col, coutures d'épaules un peu surbaissées et manches: courtes ou au-dessous des coudes à ourlets piqués, ou longues simulant 2-pièces plissées dans poignets boutonnés, ou sans manches. Ourlet étroit. A: ourlet en découpe; A,B,C,D: variations de poches (à rabats pour B,D). D,E: fentes de côtés.

**MERCERIE:** Haut A,B,C,D,E: Boutons (13mm): 9 pour A,B,D; 7 pour C,E.

**TISSUS:** Crêpe ou lin fins - Shirting de coton. Grandes diagonales ne conviennent pas. \*avec sens. \*\*sans sens.

TAILLE	(6	8	10)	(12	14	16)	(18	20	22)
--------	----	---	-----	-----	----	-----	-----	----	-----

Largeurs des tissus données en centimètres.

**HAUT A**

115**	1.9	2.1	2.1	2.3	2.3	2.6	2.6	2.6	2.8
150**	1.5	1.5	1.5	1.6	1.6	1.8	1.8	1.9	1.9

**ENTOILAGE THERMOCOILLANT A**

51, 61	0.6	0.6	0.6	0.6	0.6	0.6	0.6	0.7	0.7
--------	-----	-----	-----	-----	-----	-----	-----	-----	-----

**HAUT B**

115**	1.2	1.4	1.4	1.6	1.6	1.9	1.9	1.9	2.1
150**	1.1	1.1	1.2	1.2	1.2	1.3	1.3	1.3	1.3

**ENTOILAGE THERMOCOILLANT B**

51, 61	0.4	0.6	0.6	0.6	0.6	0.6	0.6	0.7	0.7
--------	-----	-----	-----	-----	-----	-----	-----	-----	-----

**HAUT C**

115**	1.4	1.6	1.6	1.9	1.9	2.1	2.1	2.1	2.3
150**	1.3	1.3	1.3	1.3	1.3	1.4	1.4	1.4	1.4

**ENTOILAGE THERMOCOILLANT C**

51, 61	0.3	0.6	0.6	0.6	0.6	0.6	0.6	0.7	0.7
--------	-----	-----	-----	-----	-----	-----	-----	-----	-----

**HAUT D**

115**	1.3	1.3	1.3	1.5	1.5	1.8	1.8	1.8	1.9
150**	1.1	1.1	1.1	1.1	1.1	1.2	1.2	1.2	1.2

**ENTOILAGE THERMOCOILLANT D**

51, 61	0.4	0.6	0.6	0.6	0.6	0.6	0.6	0.7	0.7
--------	-----	-----	-----	-----	-----	-----	-----	-----	-----

**HAUT E**

115**	1.3	1.5	1.5	1.8	1.8	2.0	2.1	2.1	2.1
150**	1.1	1.1	1.2	1.2	1.3	1.3	1.3	1.3	1.3

**ENTOILAGE THERMOCOILLANT E**

51, 61	0.3	0.6	0.6	0.6	0.6	0.6	0.6	0.7	0.7
--------	-----	-----	-----	-----	-----	-----	-----	-----	-----

**LARGEURS à l'ourlet**

A	102	104	107	109	115	120	125	130	135
B,C,D,E	94	97	99	102	107	112	117	122	127

**LONGUEURS dos, votre nuque à l'ourlet**

A	78	78	79	80	80	81	81	82	83
B,C,D	59	59	60	61	61	62	62	63	64
E	69	69	70	71	71	72	72	73	74

**(d)** List **three** fabrics suggested for the pattern.

1 .....

2 .....

3 .....

[3]

**(e)** What is the size of buttons needed for top A, B, C, D and E?

.....

[1]

**(f)** List **six** points of information that can be found at the back of the pattern envelope.

1 .....

2 .....

3 .....

4 .....

5 .....

6 .....

[6]

**(g)** List **four** pieces of information that can be found in front of the pattern envelope.

1 .....

2 .....

3 .....

4 .....

[4]

[30]

2 Study the following pattern piece and answer the questions.

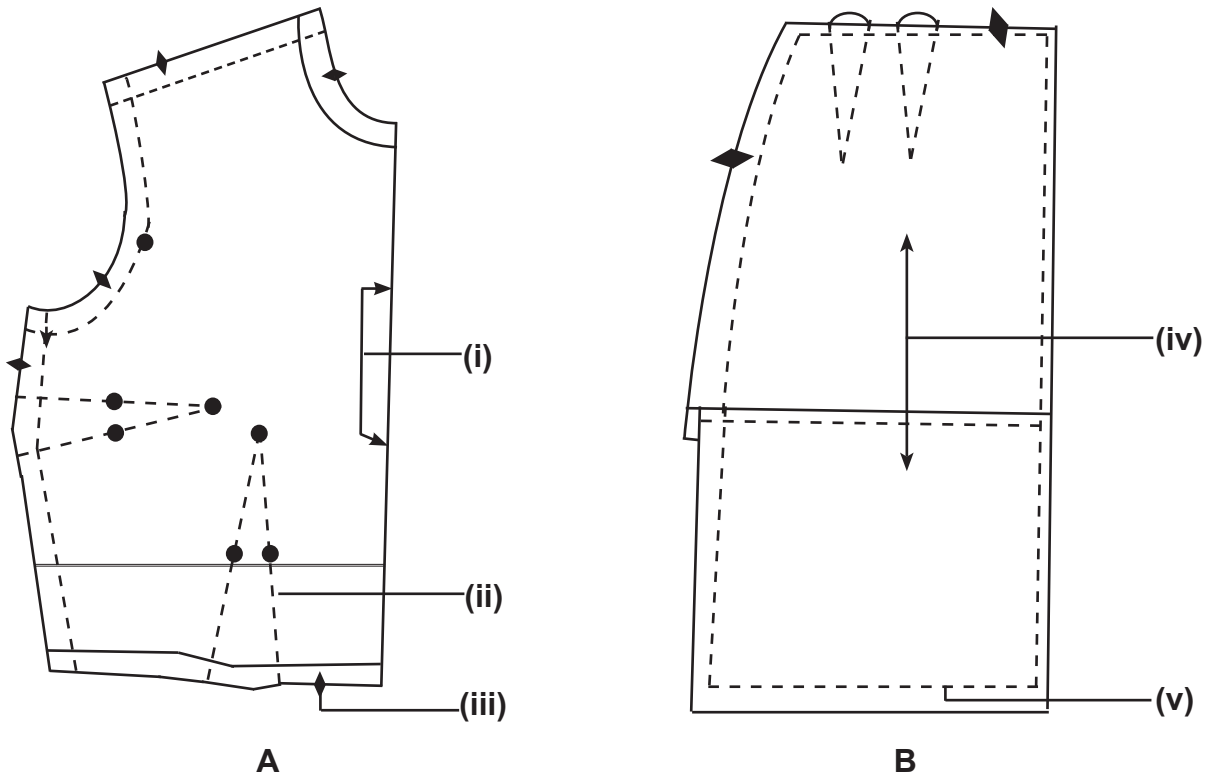

(a) Name the pattern piece **A** and **B**.

**A** .....

**B** ..... [2]

(b) Identify pattern markings **(i)**, **(ii)**, **(iii)**, **(iv)** and **(v)**.

**(i)**.....

**(ii)**.....

**(iii)**.....

**(iv)**.....

**(v)**..... [5]

(c) Describe how pattern pieces can be shortened.

.....  
.....  
.....  
.....  
.....  
.....  
.....  
.....  
.....  
.....  
.....

[5]

(d) State the purpose of the following pattern markings:

(i) Adjustment line

.....  
.....

[2]

(ii) Dots/circles

.....  
.....

[2]

(iii) Stitching direction

.....  
.....

[2]

(e) Draw the following pattern markings:

(i) Buttonhole position

[1]

(ii) Stitching line

[1]

[20]

**SECTION B**

For Examiner's Use

**3 (a)** Define the following terms:

**(i)** *Comfort*

.....  
 ..... [2]







**(ii)** *Durability*

.....  
 ..... [2]

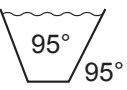
**(iii)** *Colour fastness*

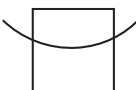
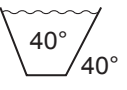
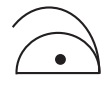
.....  
 ..... [2]

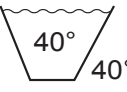
**(b)** Study the following information given and answer the questions which follows:

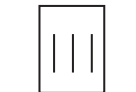
blouse	price	strength	wash	iron	dry	alkalis/ acids
cotton	N\$120.00	Stronger wet than dry				White cotton turns yellow
polycotton 'cotton rich'	N\$100.00	Strong wet or dry				No marked effect
polyester	N\$89.50	Strong				Acids weaken

**(i)** Which is the cheapest blouse?

.....  
 ..... [1]

**(ii)** Which blouse is regarded as the best buy in terms of the range of characteristics?

.....  
 ..... [1]

**(iii)** Which blouse is made from a pure synthetic fibre?

..... [1]

**(iv)** Which blouse is a mixture of fibres?

..... [1]



(c) List **three** fabrics made from:

(i) Cotton

1 .....

2 .....

3 .....

[3]

(ii) Polyester

1 .....

2 .....

3 .....

[3]

(d) Cotton is strong.

Describe this statement.

.....

.....

.....

.....

[2]

(e) Describe these **three** care symbols found on a cotton garment.

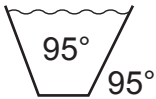

.....



.....

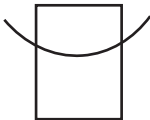

.....

[3]

[21]

4 The diagrams below show how fabrics are prepared before cutting out a garment. Study and answer the questions that follow:

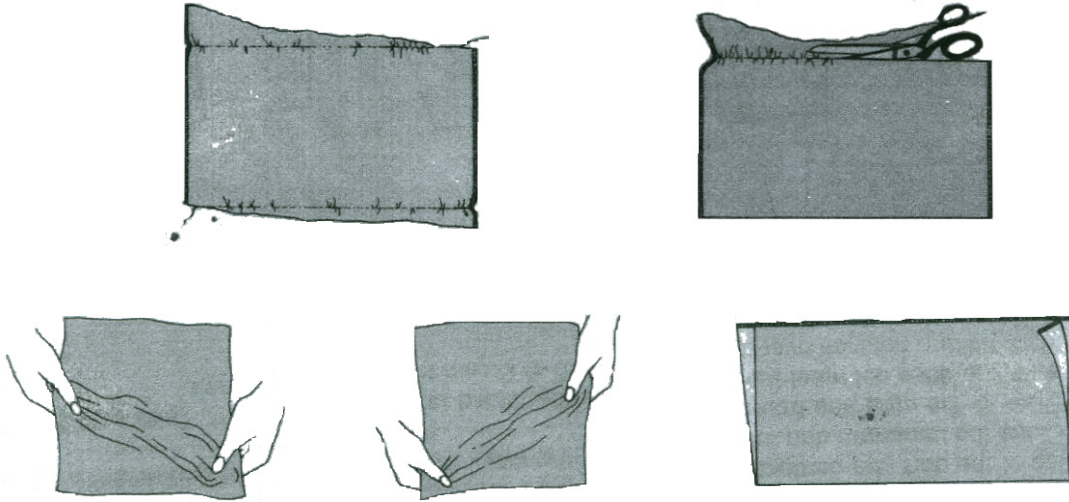

(a) Describe how to straighten the grain of the fabric.

.....

.....

.....

.....

.....

.....

.....

.....

.....

.....

.....

.....

.....

.....

.....

.....

.....

.....

.....

.....

.....

.....

[5]

(b) Explain the following terms:

(i) One way design fabrics

.....

.....

[1]

(ii) Without Nap fabrics

.....

.....

[1]

(iii) List **five** rules for laying out pattern pieces.

- 1.....  
.....
- 2.....  
.....
- 3.....  
.....
- 4.....  
.....
- 5.....  
.....

[5]

(c) Describe **four** rules for cutting out garments.

- 1.....  
.....
- 2.....  
.....
- 3.....  
.....
- 4.....  
.....

[4]

(d) List **three** methods used for transferring pattern markings.

- 1.....  
.....
- 2.....  
.....
- 3.....  
.....

[3]

[19]

5 The diagrams shows different style features for different figure types.

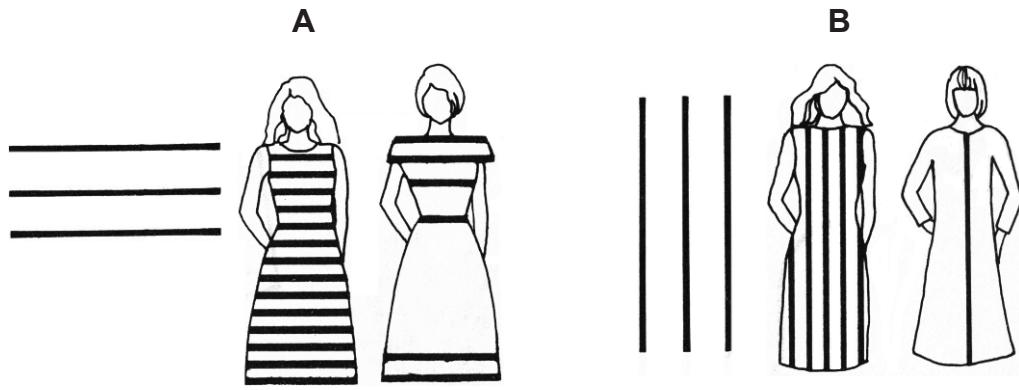

(a) Which style features are suitable for:

(i) Tall, slim figure

..... [1]

(ii) Short, well proportioned, heavy figure

..... [1]

(b) List **two** fabrics that should be avoided by a short, well proportioned, heavy figure.

1.....

2..... [2]

(c) List **three** style features suitable for a tall, heavy figure.

1.....

2.....

3..... [3]

(d) List **three** advantages of making a jacket for yourself.

1.....

2.....

3..... [3]

[10]

6 (a) Identify the following kinds of openings:

**A**

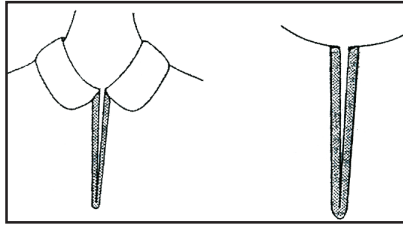

**B**

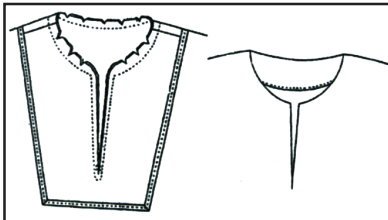

**C**

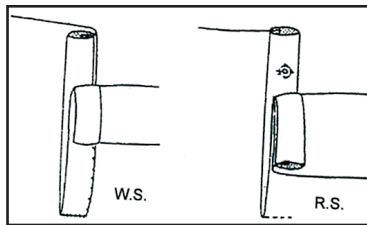

**A** .....

**B** .....

**C** .....

[3]

(b) Identify **two** fastenings which could be used on **A** and which could be used on **C**.

**A** .....

.....

[2]

**C** .....

.....

[2]

(c) Where would a bound opening be used on a garment?

.....

.....

[2]

(d) Name the strip used to complete a bound opening.

.....

[1]

[10]

7 Study the diagrams and answer the questions.

(i)

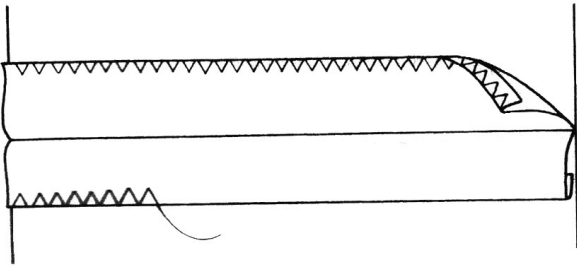

(ii)

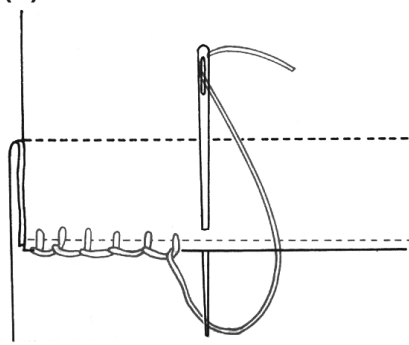

(iii)

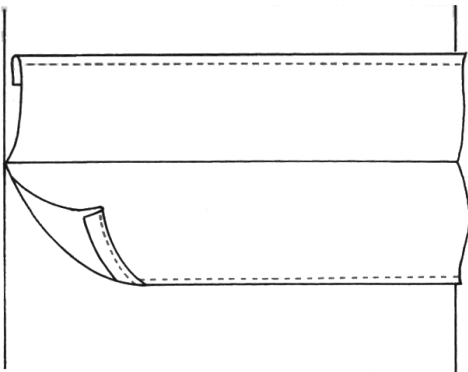

(iv)

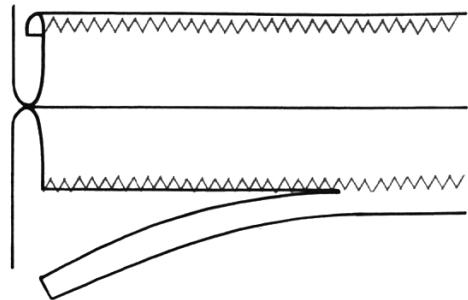

(v)

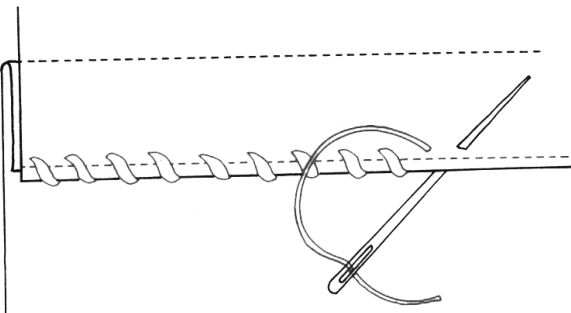

(a) Identify hem edge finishes on seams.

(i).....

(ii).....

(iii).....

(iv).....

(v).....

[5]

(b) Identify hems **A** and **B** below.

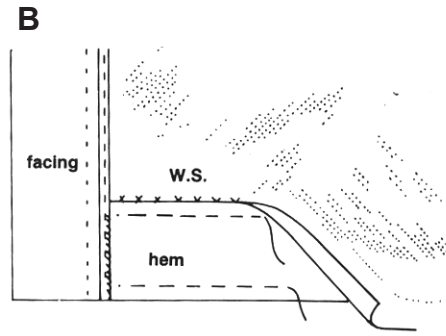
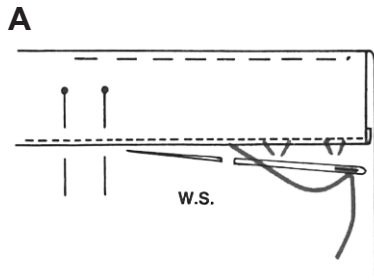

**A** .....

**B** ..... [2]

(c) Identify the following collars.

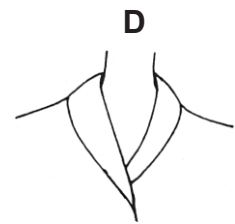
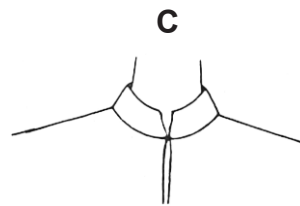
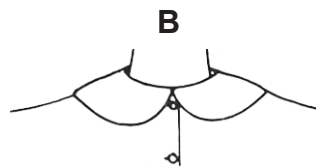
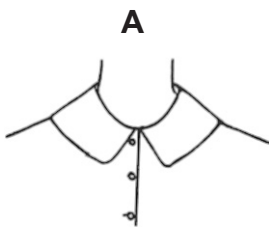

**A** .....

**B** .....

**C** .....

**D** ..... [4]

(d) Explain how to determine the correct buttonhole size.

.....  
 .....

[2]

(e) Which machine stitch is used to make a buttonhole?

.....

[1]

(f) Name the apparatus needed to cut open buttonholes.

.....

[1]

[15]

