

Centre Number	Candidate Number	Candidate Name
---------------	------------------	----------------

NAMIBIA SENIOR SECONDARY CERTIFICATE

WOODWORK ORDINARY LEVEL

6190/2

PAPER 2 PRACTICAL EXAMINATION

3 hours

Marks 50

2022

Additional Materials: As listed in Instructions to subject teachers.

INSTRUCTIONS AND INFORMATION TO CANDIDATES

- Write your name, centre number and candidate number in the spaces at the top of this page.
- Use a dark blue or black pen for written answers.
- Non-programmable calculators may be used.

Part A

- Answer all questions.
- Write your answer in the spaces provided on the Question Paper.

Part B

- Study the attached drawings carefully
- Use suitable safety equipment.
- The invigilator will take photos periodically during the examination.

Part C

- Write a brief reflection of the practical work undertaken in the spaces provided on the Question Paper.

For Examiner's Use	
Part A	
Part B	
Part C	
Total	

Marker	
Checker	

This document consists of **5** printed pages and **3** blank pages.



Republic of Namibia
MINISTRY OF EDUCATION, ARTS AND CULTURE

Part A: Planning

You are required to make a spice rack according to the given specifications.

Fig. 1 shows the wooden spice rack that is to be made.

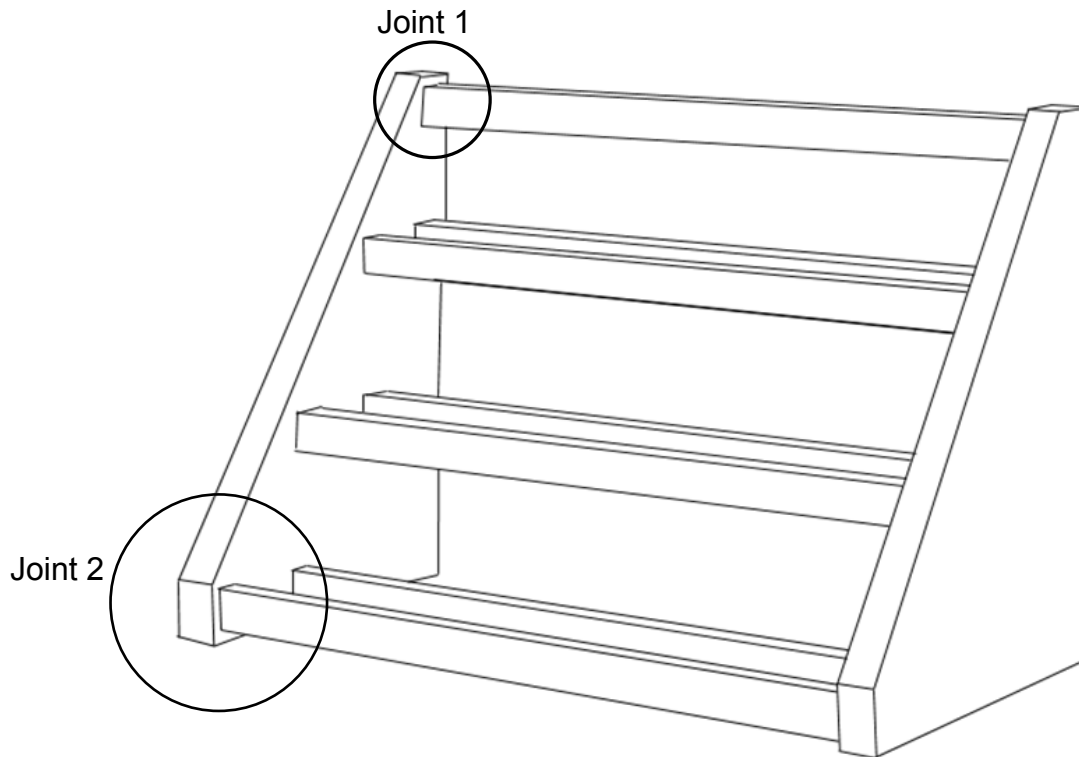

Fig. 1

List any **five** hand tools needed to produce this product.

- 1.....
- 2.....
- 3.....
- 4.....
- 5.....

[5]

Part B: Practical (the making)

Make the following artefact using the material supplied and the tools needed.

No Finishing is needed. The joints must be fitted together and must not be glued together.

The article must be made as accurately and neatly as possible in the given time.

The following may not be used:

- Sand paper
- Files or rasps
- Glue
- Electrical tools
- Take note hard board at the bottom should be nailed on the bottom to keep parts together

Fig. 2 shows an exploded view of the spice rack showing all the measurements of the parts and joints to be made.

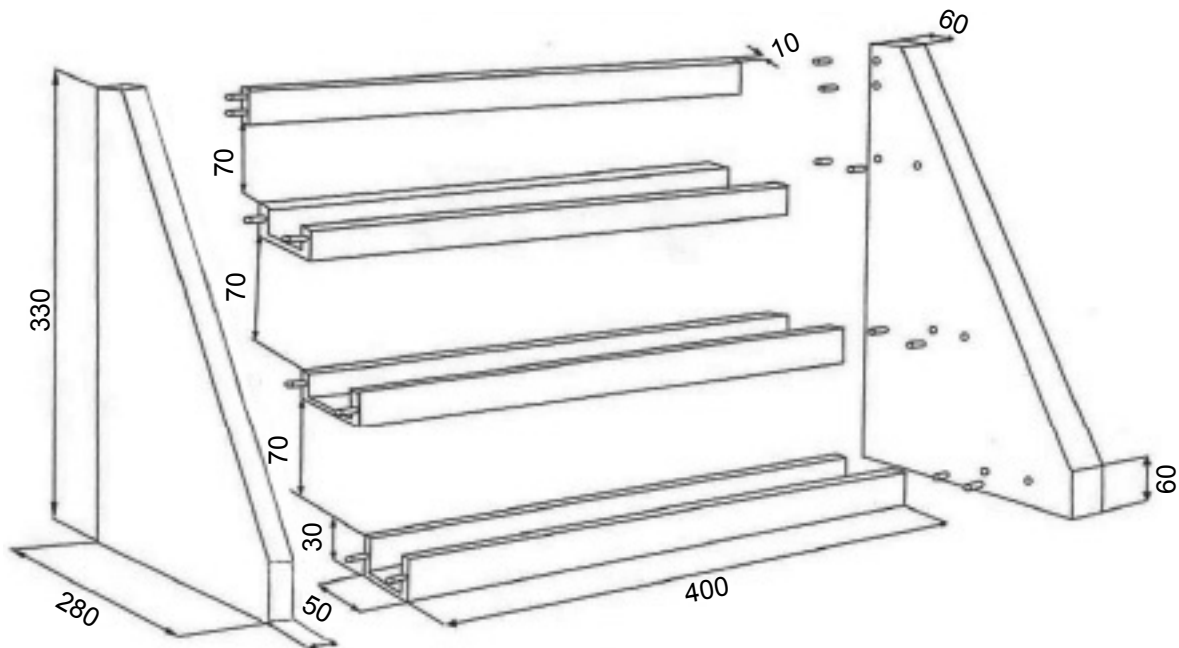

Fig. 2

[40]

Specifications

Materials per learner

All dimension are in (mm)

Quantities	Material	Dimension
2x	Marenti	400 x 250 x 16
7x	Meranti	468 x 50 x 8
3x	Hard board	468 x 60 x 3 mm
1x	Dowel stick	500 x 5 mm
30x	Hard board nails	20mm

Tools needed

- Cutting tools
- Finishing tools
- Measuring tools
- Marking off tools
- Clamping tools

Evaluation Indicators	Mark
Preparation of work pieces	5
Interpretation of drawings/specifications	5
Safe handling of tools and equipment	5
Proper use of tools and equipment	5
Safety precautions	5
Accuracy and quality of work/product	15
Total	40

Part C: Evaluation

Write a short evaluation of the product that you have made.

.....

.....

.....

.....

.....

.....

.....

.....

.....

.....

.....

.....

[5]

[50]

BLANK PAGE

BLANK PAGE

BLANK PAGE

The DNEA acknowledges the usage and reproduction of third party copyright material in the NSSC Assessment, **with and without permission** from the copyright holder. The Namibian Government Copyright Act allows copyright material to be used limitedly and fairly for educational and non-commercial purposes.

The Directorate of National Assessment and Examinations operates under the auspices of the Ministry of Education, Arts and Culture in Namibia.