DESIGN AND TECHNOLOGY

6043/12

Paper 1 Technology

October/November 2019

2 hours 30 minutes

Additional Materials: Answer Booklet/Paper.
 Plain paper.
 Sketching equipment.

READ THESE INSTRUCTIONS FIRST

If you have been given an Answer Booklet, follow the instructions on the front cover of the Booklet.

Write your centre number, candidate number and name on the work you hand in.

Write in dark blue or black pen.

You may use an HB pencil for any diagrams, graphs or rough working.

Do not use staples, paper clips, glue or correction fluid.

DO NOT WRITE IN ANY BARCODES.

Part A

Answer **all** questions.

Part B

Answer **four** questions.

Answer **two** questions from Section 1 and **two** questions from Section 2.

You are advised to spend no longer than 45 minutes on Part A.

Use sketches where appropriate to help answer any question. You may use coloured pencils.

All dimensions are in millimetres.

The number of marks is given in brackets [] at the end of each question or part question.

At the end of the examination, fasten all your work securely together.

This document consists of **12** printed pages.

Part A

Attempt **all** questions.

- 1 Fig. 1 shows a key tag made from lead free pewter.

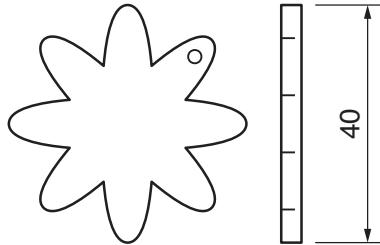

Fig. 1

Give **two** reasons why lead free pewter would be a suitable metal to use to make this key tag in a school workshop. [2]

- 2 Environmental issues are often considered when choosing materials for products.

State **two** different environmental considerations for each material given:

- (a) acrylonitrile butadiene styrene (ABS) [2]
(b) pine [2]
(c) steel. [2]

- 3 Sketch the following tools:

- (a) scribe [2]
(b) tenon saw. [2]

- 4 State what is meant by the following:

- (a) shaping a material by wasting [1]
(b) shaping a material by deforming. [1]

- 5 Fig. 2 shows a workshop tool.

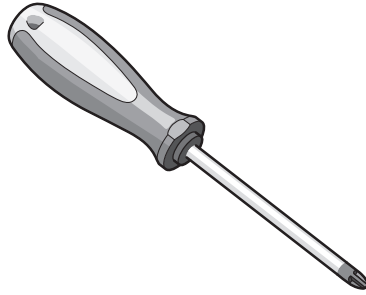

Fig. 2

- (a) Name the tool. [1]
- (b) State its purpose. [1]
- 6 State what is meant by the term 'self-finishing' when describing the properties of a material. [1]
- 7 Fig. 3 shows two pieces of mild steel that are to be brazed together.

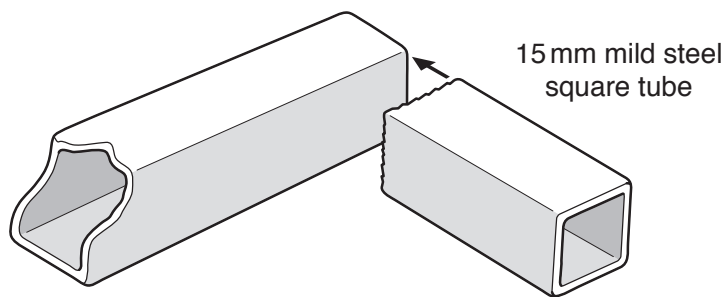

Fig. 3

Describe **three** stages required when preparing the material for brazing, giving a reason for each stage. [6]

- 8 State why you should **not** clamp wood in a metal working vice. [1]

9 Fig. 4 shows a spade.

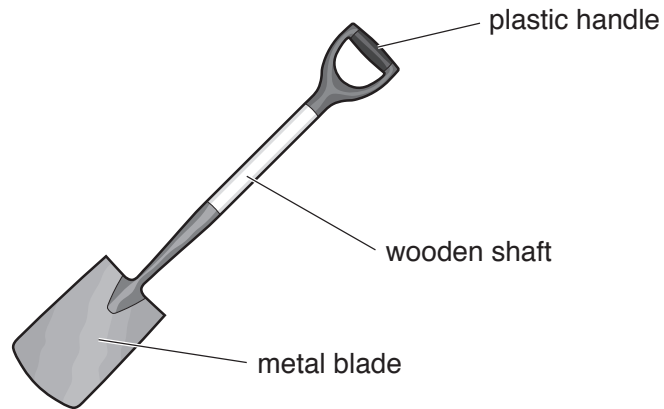

Fig. 4

Name an appropriate specific material for:

- (a) the plastic handle [1]
- (b) the wooden shaft [1]
- (c) the metal blade. [1]

10 Give **one** example of anthropometric data needed to design a spade. [1]

Part B

Attempt **four** questions, **two** from Section 1 and **two** from Section 2.

All questions carry equal marks.

Section 1 – Tools and Materials

11 Three different tools are shown in Fig. 5.

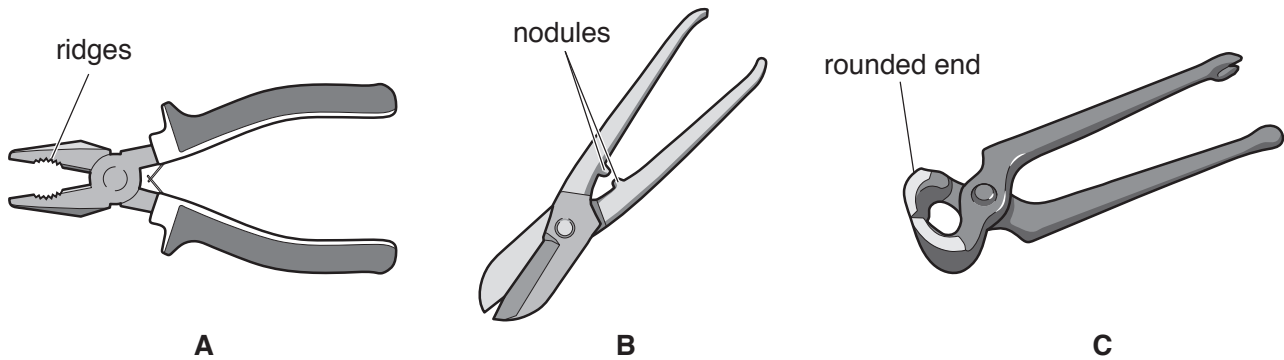

Fig. 5

- (a) Name the tools shown in Fig. 5 and state a specific use for each. [6]
- (b) Explain:
- (i) the purpose of the ridges on **A** [2]
 - (ii) the purpose of the nodules on **B** [2]
 - (iii) the purpose of the rounded end on **C**. [2]
- (c) Sketch the following and explain the purpose of each:
- (i) guillotine (bench shear) [3]
 - (ii) coping saw. [3]

12 Materials are chosen in the manufacture of products based on their properties.

(a) Copy and complete the table below onto one full page.

Give **one** use for each material and **two** properties that make the material suitable for that use.

Material	Use	Properties
Aluminium		
Mild steel		
Polyethylene		
Polystyrene		
Pine		

[15]

(b) State:

(i) what is meant by the term alloy [1]

(ii) the purpose of an alloy [1]

(iii) the name of an alloy. [1]

13 Fig. 6 shows three outdoor chairs made from different materials.

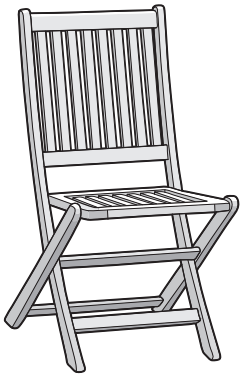

wooden chair

A



plastic chair

B

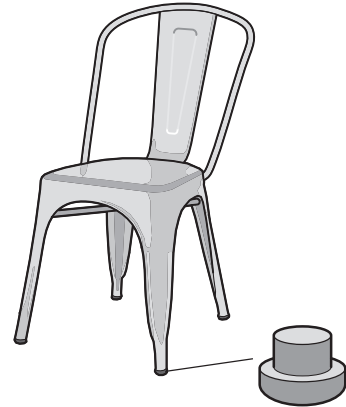

metal chair

foot

C

Fig. 6

(a) For each chair, state a suitable specific material.

Give **one** reason for each material.

[6]

(b) Chair **A** and chair **C** could be given an applied finish to make them last longer when kept outdoors.

(i) Suggest **two** suitable applied finishes for chair **A**.

[2]

(ii) Suggest **two** suitable applied finishes for chair **C**.

[2]

(c) The feet on chair **C** are made from plastic.

(i) Identify a suitable specific material that the feet could be made from.

[1]

(ii) Name a machine in the workshop that could be used to manufacture the feet.

[1]

(d) Fig. 7 shows part of a wood joint used on chair **A**.

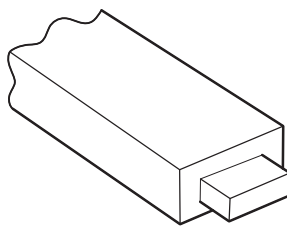

Fig. 7

Use sketches and notes to describe how this part would be made naming the tools used. [6]

14 Fig. 8 shows a hair comb.

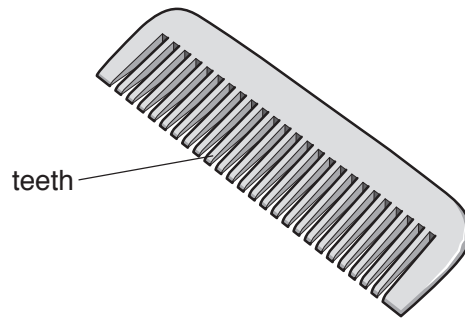

Fig. 8

(a) Identify **two** properties that would be useful in a material used to make the comb shown in Fig. 8. [2]

(b) Some materials being considered for manufacturing the comb are:

- polystyrene (HIPS)
- aluminium
- mahogany.

Give **one** reason for selecting each material and **one** reason for rejecting each material. [6]

(c) Identify a manufacturing method that could be used to ensure the teeth of the comb are identical. [1]

(d) Select **one** material from those listed in part (b). Use sketches and notes to describe how a batch of 20 identical combs could be manufactured using this material. [9]

Section 2 – Processes

15 Fig. 9 shows a hand bell.

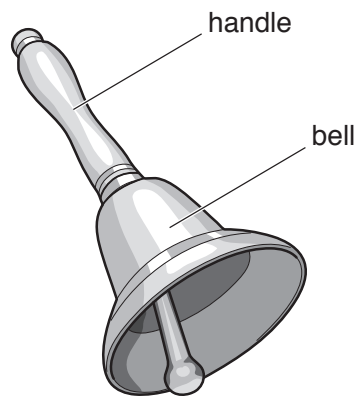

Fig. 9

- (a) (i) Name a suitable wood for the handle and give **two** reasons for your choice. [3]
(ii) Name a suitable metal for the bell and give **two** reasons for your choice. [3]
- (b) Explain how ergonomics has been considered when designing the handle. [3]
- (c) Describe how you could achieve a high quality finish on the surface of the bell. [2]
- (d) Use sketches and notes to explain how the handle would be made. [7]

16 Fig. 10 shows three different processes used in the manufacture of products.

Choose **two** of the processes. Use sketches and notes to describe each process.

Process **A**: casting a candle holder from aluminium.

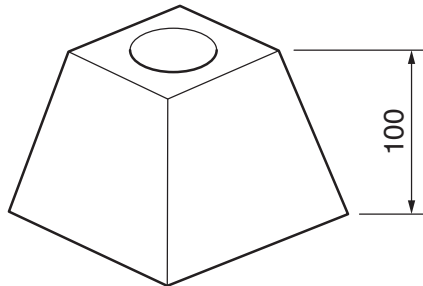

Process **B**: marking out, drilling and tapping mild steel strips to allow an M6 machine screw to hold the strips together.

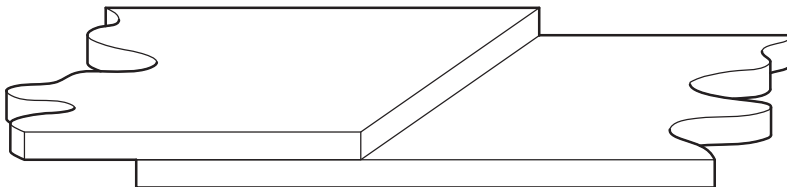

Process **C**: marking out, shaping and joining two sheets of 18 mm thick MDF using screws. The height of the material is given.

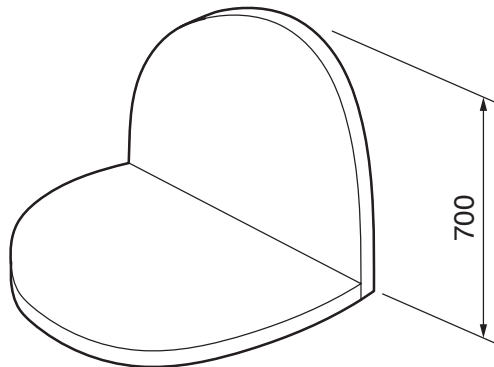

Fig. 10

[18]

17 Fig. 11 shows the design for wall art. The wall art will be made from either mild steel or plywood.

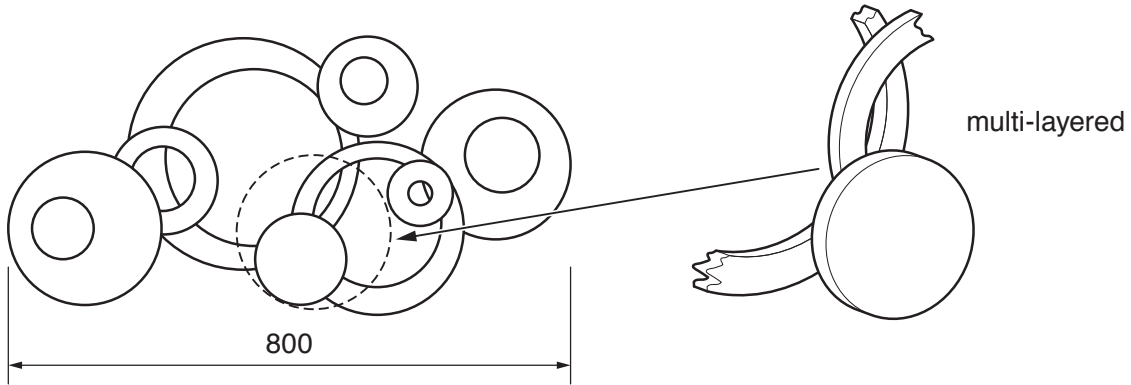

Fig. 11

(a) Describe, using sketches and notes, how the design could be made from:

(i) 1 mm mild steel sheet [6]

(ii) 9mm plywood. [6]

(b) Use sketches and notes to describe how one of the mild steel parts could be plastic coated. [6]

18 Fig. 12 shows details of a child's desk made from wood.

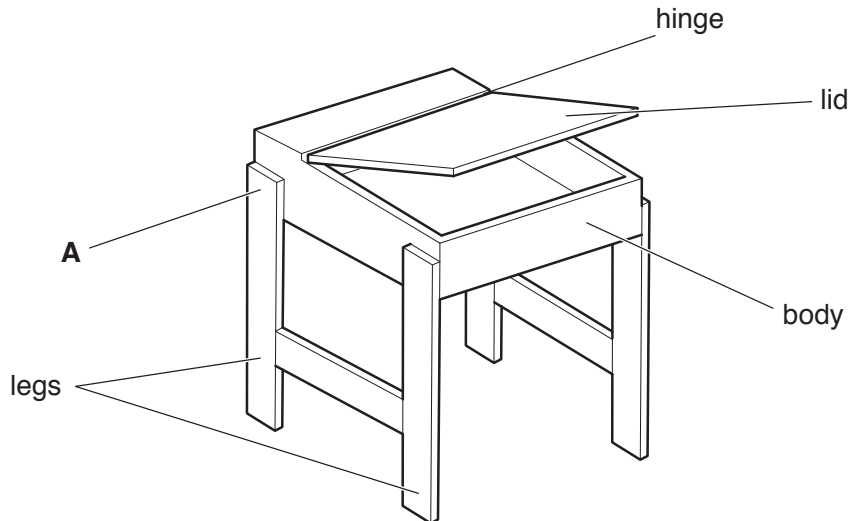

Fig. 12

- (a) Name a suitable type of hinge that could be used to connect the desk lid to the body. [1]
- (b) Use sketches and notes to explain the following processes:
- (i) how the hinge is attached to the lid and body [5]
- (ii) how the leg and body could be marked out and joined at **A**. [5]
- (c) Use sketches and notes to describe a method of keeping the lid open without it falling. [4]
- (d) Use sketches and notes to show an improvement that can be made to the desk. [3]

Permission to reproduce items where third-party owned material protected by copyright is included has been sought and cleared where possible. Every reasonable effort has been made by the publisher (UCLES) to trace copyright holders, but if any items requiring clearance have unwittingly been included, the publisher will be pleased to make amends at the earliest possible opportunity.

To avoid the issue of disclosure of answer-related information to candidates, all copyright acknowledgements are reproduced online in the Cambridge Assessment International Education Copyright Acknowledgements Booklet. This is produced for each series of examinations and is freely available to download at www.cambridgeinternational.org after the live examination series.

Cambridge Assessment International Education is part of the Cambridge Assessment Group. Cambridge Assessment is the brand name of the University of Cambridge Local Examinations Syndicate (UCLES), which itself is a department of the University of Cambridge.