

NAMIBIA SENIOR SECONDARY CERTIFICATE

WOODWORK ORDINARY LEVEL

6190/2

PAPER 2 Practical Examination

2022

INSTRUCTIONS TO SUBJECT TEACHERS

This document consists of **8** printed pages and **2** blank pages.



Republic of Namibia

MINISTRY OF EDUCATION, ARTS AND CULTURE

Instructions for the Woodwork Practical Examination Invigilator

A Assistance to candidates

The purpose of the Woodwork practical examination is to assess the candidates' ability to apply their skills related to practical work. This is done by requesting the candidates to perform practical skills in the workshop. Therefore, the candidates' ability to do practical work should not be hindered by the failure of tools, machines and materials. In order to overcome difficulties that candidates might experience during the practical examination, the invigilator should (or allow the Woodwork teacher to) assist candidates in cases where equipment is malfunctioning or materials are not giving the expected results. Teachers should test the equipment like tools and machines regularly in advance.

The following regulations must be strictly adhered to.

- Candidates will wear approved Personal Protective Equipment (PPE) for the duration of the test.
- The use of cell phones are strictly prohibited.
- A candidate who is unable to proceed and require assistance must inform the invigilator and state the difficulty.
- A report must be written of any assistance given to a candidate with the Candidate Name and Candidate Number.
- The test may be terminated by the invigilator if candidate demonstrates a lack of competency that may result in physical injury or mechanical damage.
- No assistance may be announced to the whole class.
- Candidate will clean work area, tools and equipment after completion of tasks.
- Candidate will return tools and equipment after use.

B Number of sets of tools and machines

Each work station should have enough equipment for one candidate at the beginning of each practical session. Candidates are not allowed to share equipment unless stated differently in the equipment list. It is advisable to have a few spare sets to avoid candidates from being delayed due to disfunctional equipment.

Part A: Planning

Answer the question.

You are required to make a spice rack according to the given specifications..

List any **five** hand tools needed to produce this product.

Part B: Practical Production

Each candidate should be provided with the following:

Make the following artefact using the material supplied and the tools needed.

No Finishing is needed. The joints must be fitted together and must not be glued together.

The article must be made as accurately and neatly as possible in the given time.

The following may not be used:

- Sand paper
- Files or rasps
- Glue
- Electrical tools

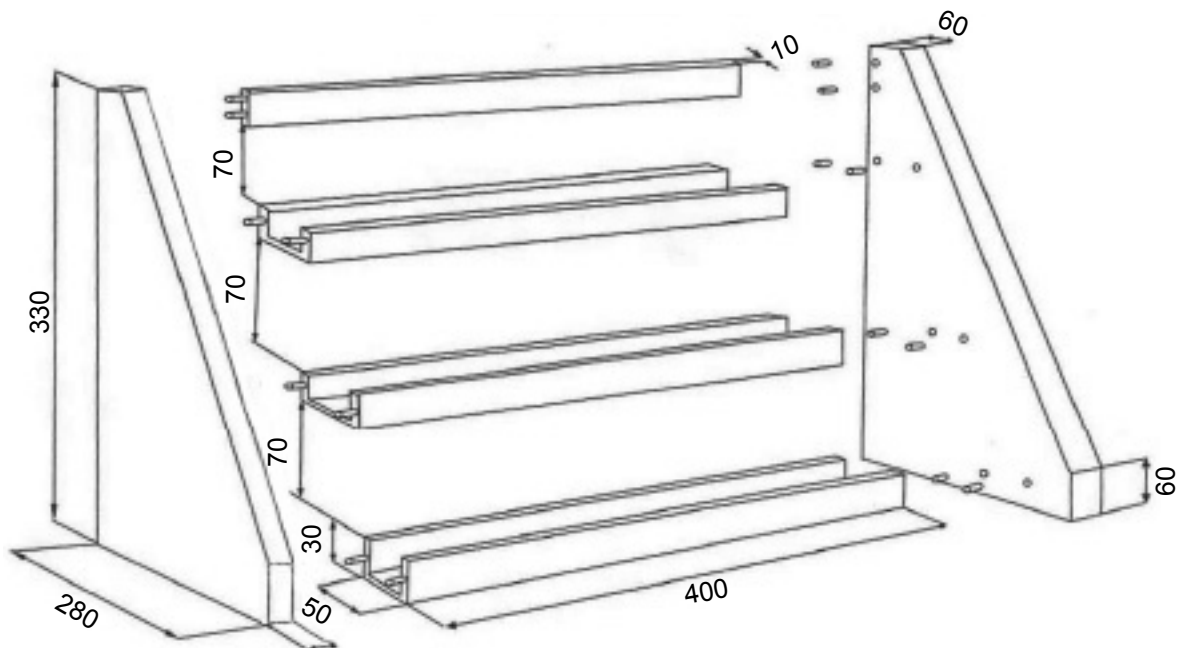

Fig. 2

The following should be prepared for each learner:

Quantities	Material	Dimensions
2x	Meranti	400x250x16
7x	Meranti	468x50x8
3x	Hard board	468x60x3mm
1x	Dowel stick	500x 5mm
30x	Hard board nails	20mm

Each learner must have access to the following equipment during the exam. All cutting tools must be sharp and all equipment must be in good working order.

Equipment

- Tenon saw/band saw/jig saw/plane
- Hand drill/drill machine
- Hammer
- 5mm drill bit
- File
- Sanding paper
- 600mm sash clamp
- Steel rule/tape measure

PART B: Practical assessment criteria

Assessment Objectives	Level of Response	Mark Range	Max. Mark
2 Interpretation of data	Limited understanding and inaccurate result of the item made.	0-1	5
	Partial understanding of the specifications given but not producing an accurate item.	2-3	
	Excellent understanding of the specifications given and producing an accurate item.	4-5	
3 Practical skills Marking out	Poor marking out skills, not using the correct tools.	0-1	5
	Moderate marking out skills, using the correct tools incorrectly.	2-3	
	Excellent marking out skills, using all tools correctly.	4-5	
4 Practical skills Safe working	Applying the safety measures using tools.	0-1	5
	Applying some safety rules, but still with the risk of injuries.	2-3	
	Applying all safety rules and works without risk.	4-5	
5 Practical skills Correct use of tools	Not using the tools in the correct manner.	0-1	5
	Using tools as they should be, but lacks the skill to do it correctly'	2-3	
	Uses all tools correctly.	4-5	
6 Practical skills Joint 1	Joint is not according to the specifications given.	0-1	5
	Joint is correct according to measurements given, but is inaccurate more than a millimeter and fits too loosely or cannot be assembled.	2-3	
	Joint is accurate and has a snug fit.	4-5	
Practical skills Joint 2	Joint is not according to the specifications given.	0-1	5
	Joint is correct according to measurements given, but is inaccurate more than a millimeter and fits too loosely or cannot be assembled.	2-3	
	Joint is accurate and has a snug fit.	4-5	

7 Accuracy and quality of products	Joints are not according to the specifications given.	0-1	5
	Joints is correct according to measurements given, but is inaccurate more than a millimeter and is not cut straight.	2-3	
	Joints is accurate and has a smooth finish	4-5	
8 Safety precautions	Wearing protective clothes.	0-1	5
	Correct use of tools and machines	2-3	
	Storing tools correctly.	4-5	

Part C: Evaluation

Each candidate should write a short evaluation of the product that they have made:

REPORT FORM
Republic of Namibia
NAMIBIA SENIOR SECONDARY CERTIFICATE

WOODWORK ORDINARY LEVEL

6190/2

PAPER 2 Practical Examination

Question Paper & Examination Security Declaration

Region.....Date.....

Centre Number.....Centre Name.....

Principal (full name, print).....

Head of Examination Centre (full name, print).....

Hereby it is certified that this examination was conducted under appropriate measures and conditions as stipulated in the 'Rules & Regulations for the NSSC Examinations'.

Attached are the following details;

1 Subject Teacher's Results

*Please submit details of the readings obtained in **Part B** on a Woodwork Practical examination assessment summary form showing the candidate's information.*

*It is essential that each packet of candidates' scripts contains a copy of the applicable **Subject Teacher's Results** as the candidates' work cannot be assessed accurately without such information.*

2 The Candidate Numbers of candidates attending each session were:

Please write them in their sitting order.

First Session	Second Session	Third Session

INSTRUCTIONS FOR COMPLETING PRACTICAL ASSESSMENT SUMMARY FORM

- 1 Complete the information on top of the form.
- 2 List the candidates in an order which will allow ease of transfer of information to a computer-printed practical mark sheet MS1 at a later stage (i.e., in candidate index number order, where the list is known; see item B.1 below). Show the teaching group or set for each candidate. The initials of the teacher may be used to indicate a group or set.
- 3 Transfer each candidate's marks to this form as follows:
 - (a) Where there are columns for individual skills or assignments enter marks initially awarded (i.e. before internal moderation has taken place).
 - (b) In the column headed 'Total Mark', enter the total mark awarded before internal moderation has taken place.
 - (c) In the column headed 'Internal Moderated Mark', enter the total mark awarded after internal moderation has taken place.
- 4 Both the teacher completing the form and the internal moderator (or moderators) should check the form and complete and sign the bottom portion.
- 5 Photographic evidence should be attached to each candidates' question paper. Each learner must have access to the following equipment during the exam. All cutting tools must be sharp and all equipment must be in good working order.
 - (a) Where there are columns for individual skills or assignments enter marks initially awarded (i.e. before internal moderation has taken place).
 - (b) In the column headed 'Total Mark', enter the total mark awarded before internal moderation has taken place.
 - (c) In the column headed 'Internal Moderated Mark', enter the total mark awarded after internal moderation has taken place.
- 6 Both the teacher completing the form and the internal moderator (or moderators) should check the form and complete and sign the bottom portion.
- 7 Photographic evidence should be attached to each candidates' question paper.

ANNEXE B: Woodwork Practical examination assessment summary form

Please read the instructions printed overleaf before completing this form.

Centre number	Centre name		November	2	0	Total mark	Internally moderated mark						
	Candidate name	Teaching group/set											
Candidate number		Part A Short questions (Planning)		Part B (practical) Making (max 40)					Part C Reflection (Evaluation)	(max 5)	(max 50)	(max 50)	
Candidate name		(max 5)		Interpretation of drawing & specifications (max 5)	Preparation of work piece(s) Marking out (max 5)	Safe handling of tools & equipment (max 5)	Proper use of tools and equipment (max 5)	Joint 1 (max 5)					Joint 2 (max 5)
Name of teacher completing this form				Signature								Date	
Name of internal moderator				Signature								Date	

BLANK PAGE

BLANK PAGE

The DNEA acknowledges the usage and reproduction of third party copyright material in the NSSC Assessment, **with and without permission** from the copyright holder. The Namibian Government Copyright Act allows copyright material to be used limitedly and fairly for educational and non-commercial purposes.

The Directorate of National Assessment and Examinations operates under the auspices of the Ministry of Education, Arts and Culture in Namibia.